

# SONY®

4-562-025-11 (1)

# Solid-State Memory Camcorder

## Operating Instructions

Before operating the unit, please read this manual thoroughly and retain it for future reference.

PXW-FS7

**XDCAM**

**XQD™**

**HDMI**

**MPEG HD422**

**Exmor**  
Super35 CMOS

**XAVC**

# Table of Contents

---

## Overview

<b>System Configuration .....</b>	<b>6</b>
<b>Location and Function of Parts .....</b>	<b>7</b>
Viewfinder .....	11
Eyepiece .....	11
Lens (PXW-FS7K only) .....	11
Grip Remote Control .....	11
Infrared Remote Control .....	12
Extension Unit (Option) .....	12
<b>Screen Display .....</b>	<b>13</b>
Viewfinder Screen .....	13
Status Screen .....	15

---

## Preparation

<b>Power Supply .....</b>	<b>18</b>
Using a Battery Pack .....	18
<b>Attaching Devices .....</b>	<b>20</b>
Attaching the Microphone Holder .....	20
Attaching the Viewfinder .....	21
Attaching the Eyepiece .....	22
Attaching a Lens .....	23
Attaching the Grip Remote Control .....	24
<b>Setting the Clock .....</b>	<b>25</b>
<b>Configuring Basic Camcorder Operation .....</b>	<b>26</b>
Shooting Mode .....	26
Color Space .....	26
<b>Using XQD Memory Cards .....</b>	<b>26</b>
About XQD Memory Cards .....	26
Inserting an XQD Memory Card .....	27
Ejecting XQD Memory Cards .....	27
Switching Between XQD Memory Cards .....	27
Formatting (Initializing) XQD Memory Cards .....	27
Checking the Remaining Recording Time .....	27
<b>Using a Utility SD Card .....</b>	<b>28</b>
Supported SD Cards .....	28
Inserting an SD Card .....	28
Ejecting the SD Card .....	28

Formatting (Initializing) SD Cards .....	29
Checking the Remaining Capacity .....	29
<b>Using the XDCA-FS7 .....</b>	<b>29</b>
Attaching the XDCA-FS7 .....	29
Removing the XDCA-FS7 .....	30
Attaching the Battery Pack .....	30
Removing the Battery Pack .....	31
Switching the Timecode Input/Output .....	31
<b>Using an HXR-IFR5 and AXS-R5 .....</b>	<b>31</b>
Connecting the HXR-IFR5 to the Camcorder .....	31
Removing the HXR-IFR5 .....	31
<b>Using the Infrared Remote Control .....</b>	<b>32</b>
<b>Using Wi-Fi Remote Control .....</b>	<b>33</b>

---

## Shooting

<b>Basic Operation Procedure .....</b>	<b>35</b>
Adjusting the Focus Automatically .....	36
Adjusting the Focus Manually .....	36
Monitoring Audio .....	37
Switching Between XQD Memory Cards .....	37
<b>Changing Basic Settings .....</b>	<b>38</b>
Selecting the Recording Format .....	38
Adjusting the Brightness .....	38
Adjusting for Natural Colors (White Balance) .....	39
Setting the Audio to Record .....	40
Specifying Time Data .....	41
<b>Useful Functions .....</b>	<b>42</b>
Assignable Buttons/Dials .....	42
Slow & Quick Motion .....	43
Picture Cache Recording (Picture Cache Rec) .....	43
Reviewing a Recording (Rec Review) .....	44
Self Portrait Mode .....	44
Displaying Peaking .....	45
Displaying Zebra .....	45
Obtaining Location Information (GPS) .....	46
Shooting in Cine EI Mode .....	46
Recording RAW Video .....	46
<b>Connecting Devices using Wireless LAN .....</b>	<b>47</b>
Attaching the IFU-WLM3 .....	48
Attaching the CBK-WA100 .....	48
One-touch Connection of NFC-enabled Devices (Using IFU-WLM3 Only) .....	49
<b>Displaying the Wi-Fi Remote Control .....</b>	<b>50</b>

---

## Thumbnail Screen

<b>Thumbnail Screen .....</b>	<b>51</b>
Screen Layout .....	51
<b>Playing Clips .....</b>	<b>52</b>
Playing Recorded Clips .....	52
<b>Clip Operations .....</b>	<b>53</b>
Thumbnail Menu Operations .....	53
Thumbnail menu items .....	53

---

## Menu Display and Settings

<b>Setup Menu Configuration and Hierarchy .....</b>	<b>54</b>
Setup Menu Organization .....	54
<b>Setup Menu Operations .....</b>	<b>56</b>
<b>Setup Menu List .....</b>	<b>57</b>
User Menu .....	57
Edit User Menu .....	58
Camera Menu .....	58
Paint Menu .....	63
Audio Menu .....	69
Video Menu .....	70
VF Menu .....	72
TC/UB Menu .....	76
Recording Menu .....	77
Thumbnail Menu .....	78
Media Menu .....	79
File Menu .....	80
System Menu .....	82

---

## External Device Connection

<b>Connecting External Monitors and Recording Devices .....</b>	<b>89</b>
<b>External Synchronization .....</b>	<b>90</b>
<b>Managing/Editing Clips using a Computer .....</b>	<b>91</b>
Connecting using a USB Cable .....	91

---

## Appendix

<b>Usage Precautions .....</b>	<b>93</b>
<b>Output Formats and Limitations .....</b>	<b>94</b>
Video Formats and Output Signals .....	94
<b>Operation Warnings .....</b>	<b>105</b>
Error Messages .....	105
Warning Messages .....	105
Caution and Operation Messages .....	106
<b>Licenses .....</b>	<b>107</b>
MPEG-4 Visual Patent Portfolio License .....	107
MPEG-2 Video Patent Portfolio License .....	107
Obtaining Software Under the GPL/LGPL License .....	108
END USER LICENSE AGREEMENT .....	108
Open Software Licenses .....	113
<b>Specifications .....</b>	<b>113</b>
General .....	113
Camera Section .....	115
Audio Section .....	115
Input/Output Section .....	115
Display Section .....	116
Media Slot Section .....	116
Supplied Accessories .....	116
Software Downloads .....	117
Trademarks .....	118

## Overview

# System Configuration

This section shows an example of a camera system configuration.

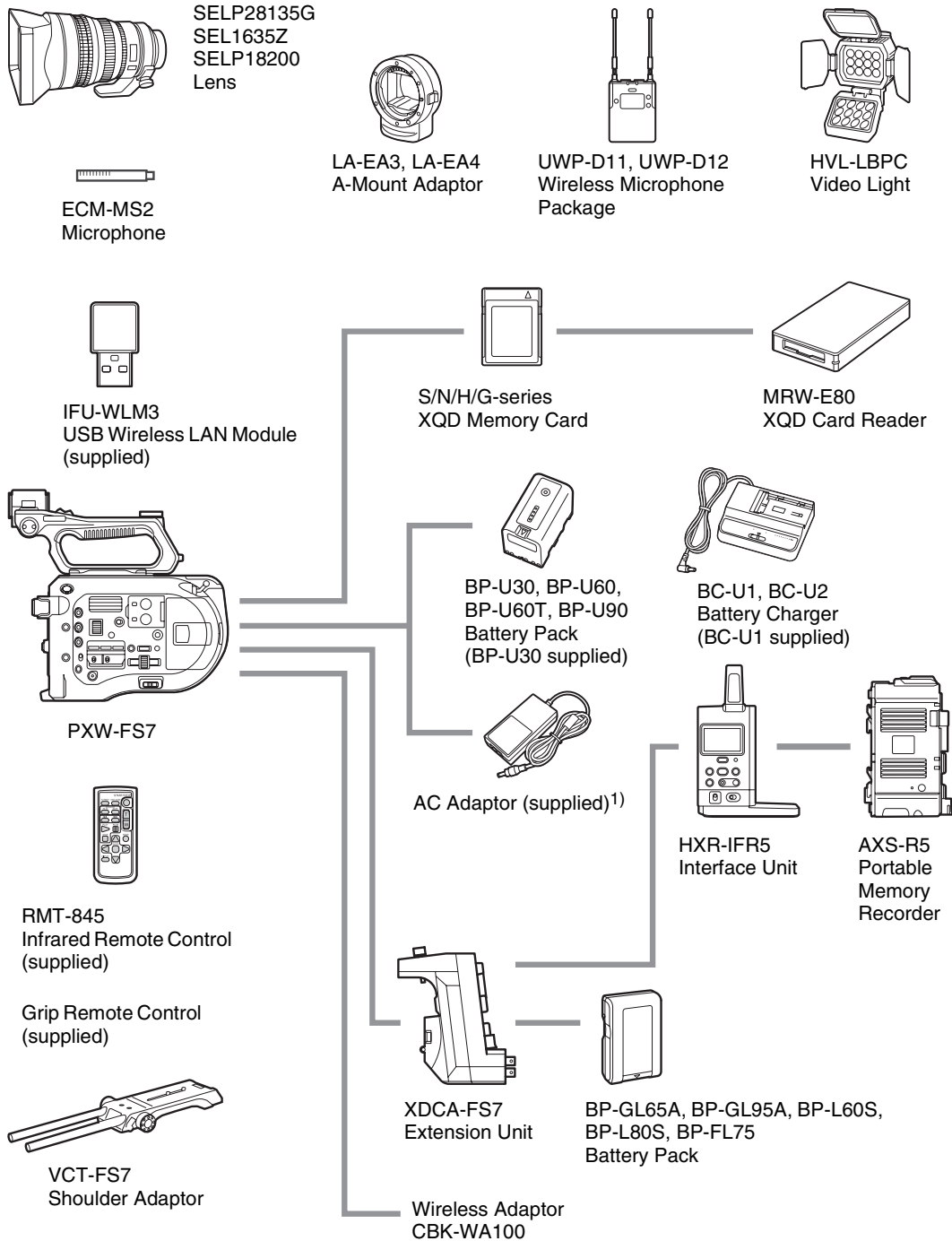

1) MPA-AC1 (USA and Canada model only)  
AC-NB12A (except USA and Canada model)

## Location and Function of Parts

For details about the usage and function of each part, see the referenced page.

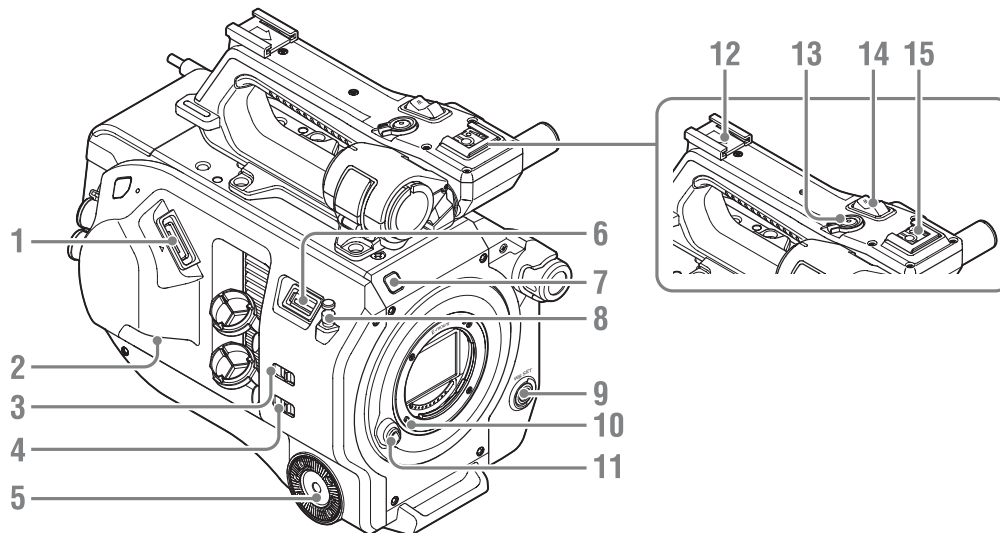

1. **Viewfinder connector** (page 21)
2. **REMOTE connector** (page 24)
3. **INPUT1 (LINE/MIC/MIC+48V) switch** (page 40)
4. **INPUT2 (LINE/MIC/MIC+48V) switch** (page 40)
5. **Grip attachment** (page 24)
6. **USB wireless LAN module connector**
7. **Recording indicator** (page 85)  
Flashes when the remaining capacity on the recording media or battery is low.
8. **Tape measure hook**  
The tape measure hook is on the same plane as the image sensor. To measure the distance between the camcorder and the subject accurately, use this hook as a reference point. You can attach the end of a tape measure to the hook to measure the distance from the subject.
9. **WB SET (white balance set) button** (page 40)
10. **Lens lock pin** (page 23)
11. **Lens release button** (page 23)

12. **Accessory shoe**
13. **Handle record START/STOP button**  
The record button cannot be operated when the lock lever is in the lock position.
14. **Handle zoom lever** (page 61)
15. **Multi-interface shoe**

**ni** Multi  
Interface Shoe

For details about accessories supported by the multi-interface shoe, contact your sales representative.

### Attaching the Accessory Shoe

1 Lift the front edge of the shoe spring, and pull the spring in the opposite direction to the arrow engraved on the spring.

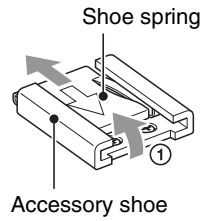

- 2 Position the accessory shoe on the accessory shoe mount, aligning the protrusions on the shoe with the corresponding points on the mount, and tighten the four screws.
- 3 Insert the shoe spring in the direction of the arrow so that the U-shaped portion fits onto the end of the accessory shoe.

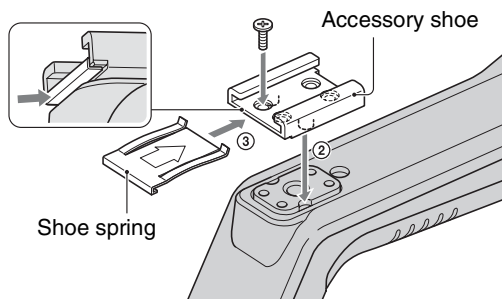

### Removing the Accessory Shoe

Remove the shoe spring as described in step 1 in "Attaching the Accessory Shoe," unscrew the four screws, and remove the accessory shoe.



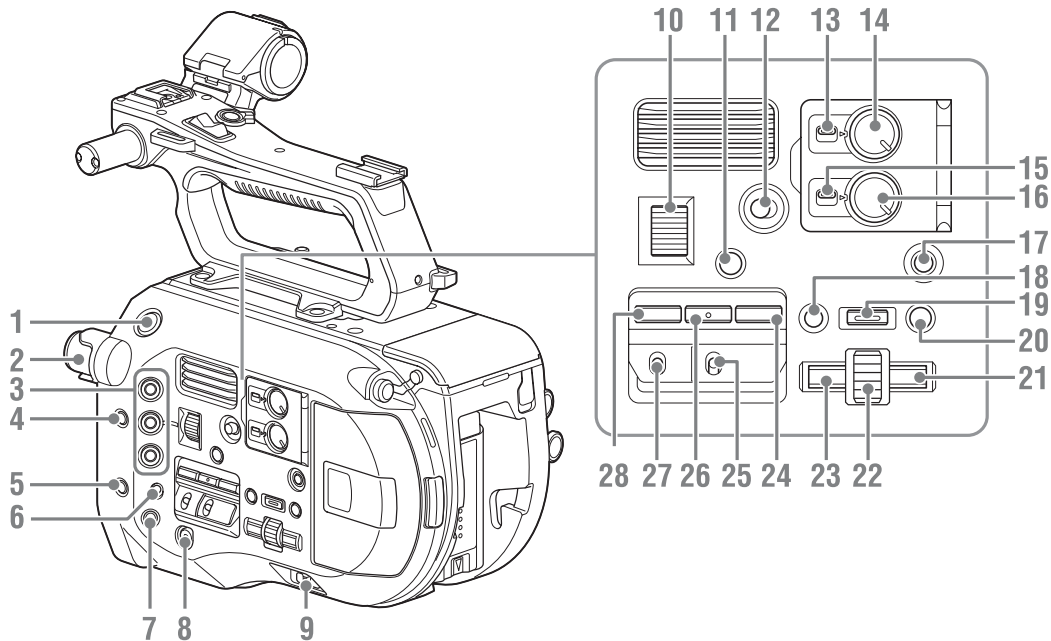

- 1. START/STOP button**
- 2. ND FILTER switch** (*page 39*)
- 3. ASSIGN (assignable) 1 to 3 buttons** (*page 42*)
- 4. PUSH AUTO IRIS button** (*page 38*)
- 5. PUSH AUTO FOCUS button** (*page 36*)
- 6. FOCUS switch** (*page 36*)
- 7. DISPLAY button** (*page 13*)
- 8. FULL AUTO button** (*page 35*)
- 9. POWER switch** (*page 18*)
- 10. IRIS dial** (*page 42*)
- 11. STATUS CHECK button** (*page 15*)
- 12. HOLD switch** (*page 85*)
- 13. CH1 (AUTO/MAN) switch** (*page 40*)
- 14. AUDIO LEVEL (CH1) dial** (*page 40*)
- 15. CH2 (AUTO/MAN) switch** (*page 40*)
- 16. AUDIO LEVEL (CH2) dial** (*page 40*)
- 17. SLOT SELECT (XQD memory card select) button** (*page 27*)
- 18. CANCEL/BACK button** (*page 52*)
- 19. MENU button** (*page 54*)
- 20. THUMBNAIL button** (*page 51*)
- 21. Right button**  
Used to set numeric values and to move the cursor to the right on thumbnail screens and menus.
- 22. SEL/SET (select/set) dial**  
Turn the dial to move the cursor up/down to select menu items or settings. Press to apply the selected item.
- 23. Left button**  
Used to set numeric values and to move the cursor to the left on thumbnail screens and menus.
- 24. SHUTTER button** (*page 39*)
- 25. WHT BAL (white balance memory select) switch** (*page 39*)
- 26. WHT BAL (white balance) button** (*page 39*)
- 27. GAIN (gain select) switch** (*page 38*)
- 28. ISO/Gain button** (*page 38*)

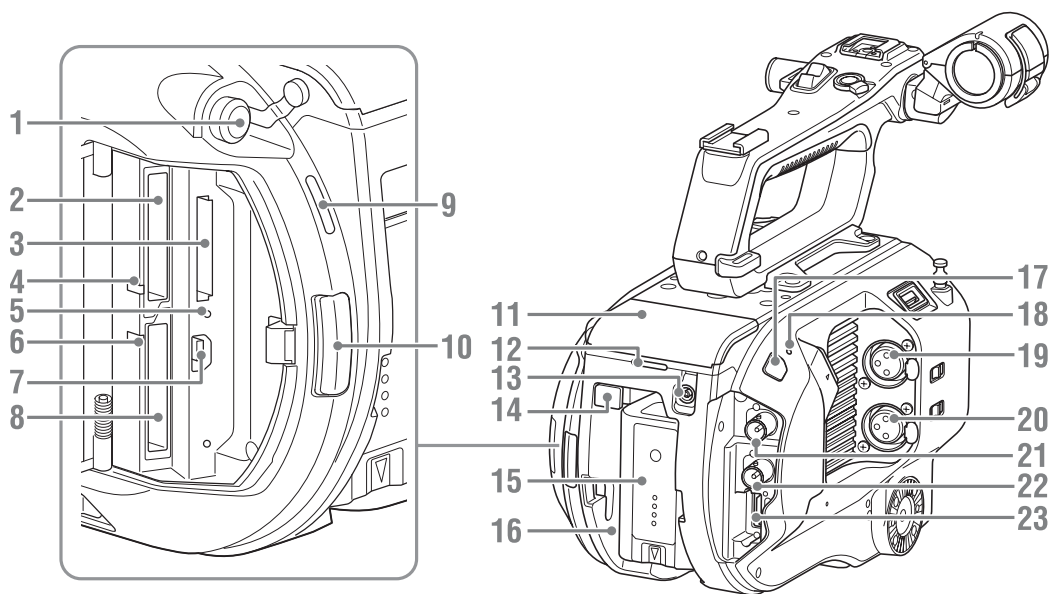

1. Headphone connector (page 37)
2. XQD card slot A (page 27)
3. SD card (for saving configuration data) slot (page 28)
4. XQD (A) access indicator (page 27)
5. SD card access indicator (page 28)
6. XQD (B) access indicator (page 27)
7. USB connector  
Connect to a computer using a USB cable to access recording media in an XQD card slot on the camcorder.
8. XQD card slot B (page 27)
9. Built-in speaker (page 37)
10. Media cover release button (page 27)
11. Extension unit connector (page 29)
12. Rear recording indicator (page 35)
13. DC IN connector (page 19)
14. BATT RELEASE (battery release) button (page 18)
15. Battery (page 18)
16. Battery pack attachment (page 18)
17. Infrared remote control receiver sensor (page 32)
18. Internal microphone (page 40)
19. INPUT1 (audio input 1) connector (page 40)

20. INPUT2 (audio input 2) connector (page 40)
21. SDI OUT 1 connector (page 89)
22. SDI OUT 2 connector (page 89)
23. HDMI OUT connector (page 89)

---

### Underside

---

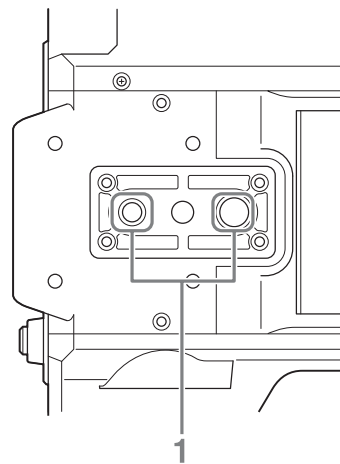

1. Tripod screw hole (1/4 inch, 3/8 inch)  
Compatible with 1/4-20UNC screws and 3/8-16UNC screws.  
Attach to a tripod (option, screw length of 5.5 mm or less).

## Viewfinder

For details about attaching the viewfinder (supplied) and eyepiece, *see page 21*.

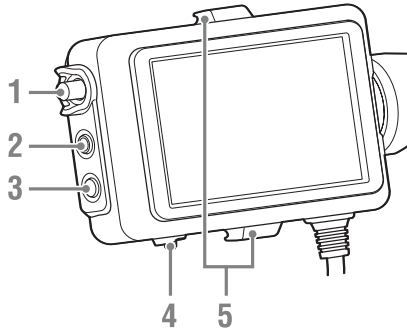

1. **CONTRAST knob**
2. **PEAKING button**
3. **ZEBRA button**
4. **MIRROR switch**
5. **Eyepiece attachment hooks**

## Eyepiece

For details about attaching the eyepiece (supplied), *see page 22*.

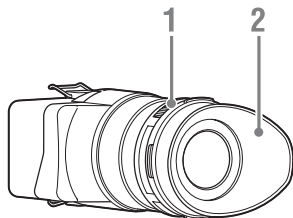

1. **Diopter adjustment knob**
2. **Eyecup**

## Lens (PXW-FS7K only)

For details, refer to the operation manual for the lens.

## Grip Remote Control

For details about attaching the grip remote control (supplied), *see page 24*.

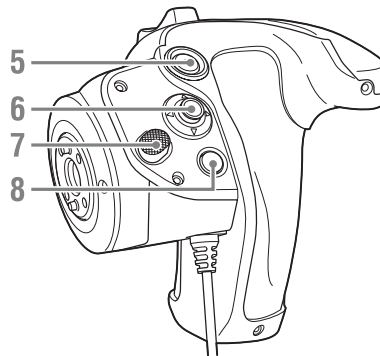
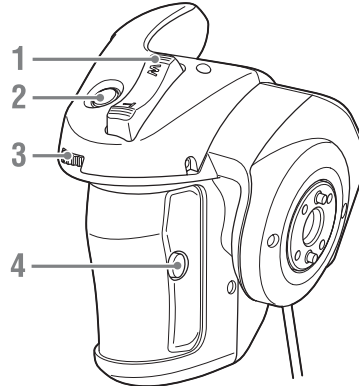

1. **Zoom lever**
2. **ASSIGN (assignable) 4 button**
3. **Assignable dial**
4. **ASSIGN (assignable) 6 button**
5. **Record START/STOP button**
6. **Multi selector**
7. **Grip rotation button**
8. **ASSIGN (assignable) 5 button**

## Infrared Remote Control

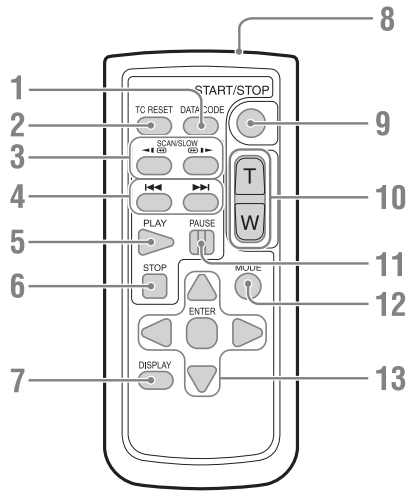

1. **DATA CODE button**  
Not used on this version.
2. **TC RESET button**
3. **SCAN/SLOW button**
4. **◀◀/▶▶ (PREV/NEXT) button**
5. **PLAY button**
6. **STOP button**
7. **DISPLAY button**
8. **Remote control transmitter**
9. **START/STOP button**
10. **Zoom lever**
11. **PAUSE button**
12. **MODE button**  
Not used on this version.
13. **◀/▶/▲/▼/ENTER button**

## Extension Unit (Option)

For details about attaching an extension unit (option), see page 29.

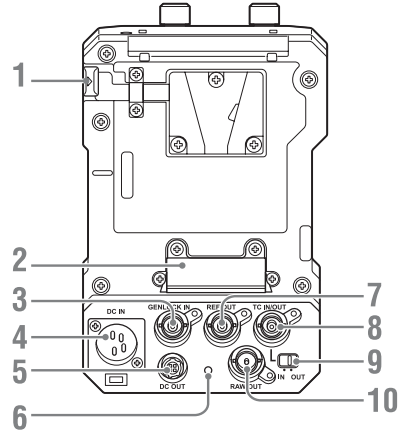

1. **BATT RELEASE button**
2. **Battery connector**
3. **GENLOCK IN**
4. **DC IN**
5. **DC OUT**
6. **Recording indicator**
7. **REF OUT**
8. **TC IN/OUT**
9. **TC IN/OUT switch**
10. **RAW OUT**

# Screen Display

## Viewfinder Screen

During shooting (recording/standby) and playback, the camcorder status and settings are superimposed on the image displayed in the viewfinder.

You can show/hide the information using the DISPLAY button.

You can also select to show/hide each item independently (*page 72*).

The 17:9 aspect ratio picture captured by the image sensor is displayed in the viewfinder. In 16:9 recording formats, the dark portions on the left and right edges are not recorded.

### Information displayed on the screen while shooting

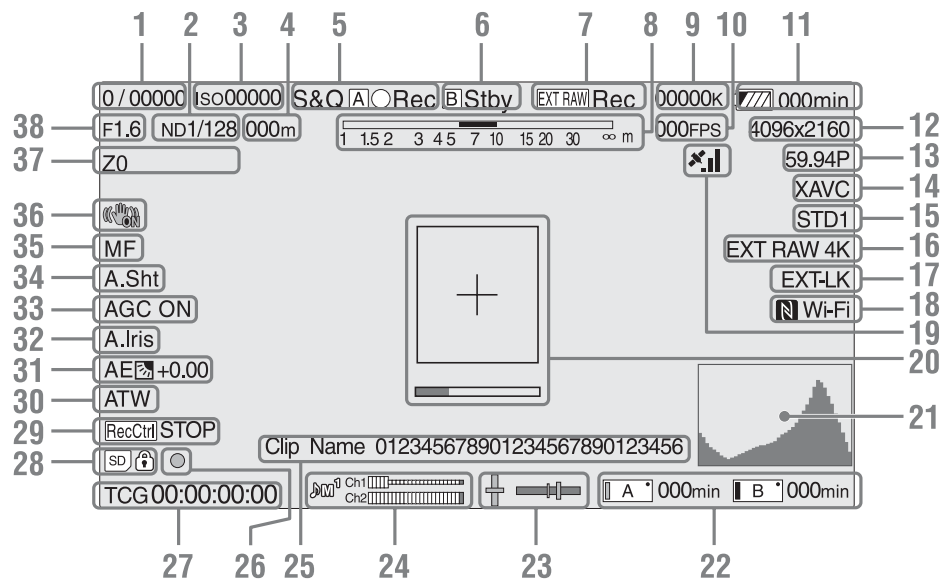

**1. Shutter mode/shutter speed indicator**  
(*page 39*)

**2. ND filter indicator** (*page 39*)

**3. Gain indicator** (*page 38*)

Displayed as an EI value when Base Setting (*page 82*) >Shooting Mode in the System menu is set to “Cine EI.”



**4. Focus position indicator**

Displays the focus position (if a lens that supports focus setting display is attached).

**5. Recording mode, slot A/B icon, and status indicators**

S&Q <b>A</b> / <b>B</b> ● Rec	Slow & Quick Motion, High Frame Rate mode recording
S&Q <b>A</b> / <b>B</b> Stby	Slow & Quick Motion, High Frame Rate mode standby
<b>A</b> / <b>B</b> ● Rec	Recording
<b>A</b> / <b>B</b> Stby	Standby
<b>A</b> / <b>B</b> ●	Picture cache recording
<b>A</b> / <b>B</b> ● Cache	Picture cache standby

## 6. Slot B icon and status indicators

 ●Rec	Recording
 Stby	Standby

## 7. External RAW recording indicator (page 46)

## 8. Depth-of-field indicator

## 9. Color temperature indicator (page 39)

## 10. S&Q Motion frame rate indicator (page 77)

## 11. Remaining battery capacity/DC IN voltage indicator (page 18)

## 12. Recording format (picture size) indicator (page 82)

Displays the picture size for recording on XQD memory cards.

## 13. Recording format (frame rate and scan method) indicator

## 14. Recording format (codec) indicator (page 38)

Displays the name of the format for recording on XQD memory cards.

## 15. Gamma/monitor LUT indicator (page 65, page 71)

Displays the gamma setting. When Shooting Mode (page 82) is set to “Cine EI,” it displays the gamma or monitor LUT setting for recording video on XQD memory cards.

## 16. External output format indicator (page 70)

## 17. Timecode external lock indicator

Displays “EXT-LK” when locked to the timecode of an external device.

## 18. Wi-Fi connection status indicator (page 47)

Displayed when the Wi-Fi function is set to “Enable.” When the IFU-WLM3 is not attached to the camcorder,  is not displayed.

## 19. GPS status indicator (page 46)

Displays the GPS status.

## 20. Focus assist indicator (page 43)

Displays a detection frame (focus area marker) indicating the area for detection of focus, and a level bar (focus assist indicator) indicating the degree of focus within that area.

## 21. Video signal indicator (page 16)

Displays a waveform, vectorscope, and histogram.

## 22. Slot A/B media status/remaining capacity indicator (page 27)

Recording media when the left side of the icon is orange.

Playback media when the green indicator on the top right of the icon is on.

## 23. Spirit level indicator

Displays the horizontal level and the front-to-rear slope in  $\pm 1^\circ$  increments up to  $\pm 20^\circ$ .

## 24. Audio level meter

## 25. Clip name indicator (page 51)

## 26. Focus indicator

## 27. Time data indicator (page 41)

## 28. SD card indicator

## 29. SDI output control status indicator (page 89)

## 30. White balance mode indicator (page 39)

W:P	Preset mode
W:A	Memory mode A
W:B	Memory mode B

## 31. AE mode indicator (page 38)

## 32. Auto iris indicator (page 38)

## 33. AGC indicator (page 38)

## 34. Auto shutter indicator (page 39)

## 35. Focus mode indicator

## 36. Image stabilization mode indicator

## 37. Zoom position indicator

Displays the zoom position in the range 0 (wide angle) to 99 (telephoto) (if a lens that supports zoom setting display is attached).

## 38. Iris position indicator

Displays the iris position (if a lens that supports iris setting display is attached).

## Information displayed on the screen during playback

The following information is superimposed on the playback picture.

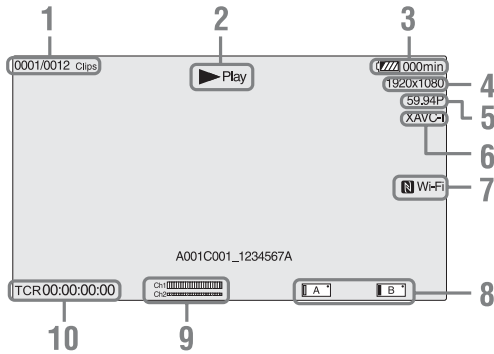

**1. Clip number / total number of clips**

**2. Playback mode**

**3. Remaining battery capacity indicator**

**4. Playback format (picture size) indicator**

**5. Playback format (frame rate) indicator**

**6. Playback format (codec) indicator**

**7. Wi-Fi connection status indicator**

(page 47)

Displayed when the Wi-Fi function is set to “Enable.” When the IFU-WLM3 is not attached to the camcorder,  is not displayed.

**8. Media indicator**

**9. Audio level indicator**

Displays the audio level when recording.

**10. Time data indicator**

When Display On/Off > Timecode in the VF menu is set to “On,” it displays the time data when the DISPLAY button is pressed.

## Status Screen

To display the status screen:

- Push the STATUS CHECK button.

To switch to the status screen:

- Turn the SEL/SET dial.
- Move the multi selector up/down.

To hide the status screen:

- Push the STATUS CHECK button.

### Camera Status screen

Displays the electronic shutter setting of the camera and the lens status.

ISO/Gain/EI<H>	ISO/Gain/EI<H> setting
ISO/Gain/EI<M>	ISO/Gain/EI<M> setting
ISO/Gain/EI<L>	ISO/Gain/EI<L> setting
Shutter	Shutter setting (Speed/Angle/ECS/Off)
Iris	F-stop value obtained from the lens
Zebra1	Zebra1 On/Off setting and level
Zebra2	Zebra2 On/Off setting and level
Gamma	Gamma Select setting
White	White balance mode and settings
Focal Length	Focal length value obtained from the lens
AE Level	AE level setting
AE Speed	AE control speed setting
AGC Limit	Maximum gain setting of the AGC function
A.SHT Limit	Fastest shutter speed of the auto shutter function
AE Mode	AE mode setting (Backlight/Standard/Spotlight)

### Audio Status screen

Displays the input setting, audio level meter, and wind noise reduction filter setting for each channel.

CH1 level meter	Channel 1 audio level meter
CH1 Source	Channel 1 input source
CH1 Ref./Sens.	Channel 1 input reference level
CH1 Wind Filter	Channel 1 microphone wind reduction filter setting
CH2 level meter	Channel 2 audio level meter
CH2 Source	Channel 2 input source
CH2 Ref./Sens.	Channel 2 input reference level
CH2 Wind Filter	Channel 2 microphone wind reduction filter setting
Monitor CH	Monitor channel setting
Headphone Out	Headphone output type setting

### System Status screen

Displays the video signal settings.

Country	NTSC or PAL region setting
Rec Format	Format for recording to XQD memory cards
Picture Size	Picture size for recording to XQD memory cards
Frame Rate	Frame rate for recording to XQD memory cards
Rec Function	Enabled special recording format and settings
Simul Rec	Simul Rec On/Off status
Picture Cache Rec	Picture Cache Rec On/Off status
Video Light Set	HVL-LBPC Video Light on/off indicator

### Video Output Status screen

Displays the SDI, HDMI, and video output settings.

SDI1	Output picture size Color space Screen display output Gamma
SDI2	Output picture size Color space Screen display output Gamma
HDMI	Output picture size Color space Screen display output Gamma
REF	Output picture size
RAW	Output picture size

### Assignable Button Status screen

Displays the functions assigned to each of the assignable buttons.

1	Function assigned to the ASSIGN 1 button
2	Function assigned to the ASSIGN 2 button
3	Function assigned to the ASSIGN 3 button
4	Function assigned to the ASSIGN 4 button
5	Function assigned to the ASSIGN 5 button
6	Function assigned to the ASSIGN 6 button
IRIS Dial	Function assigned to the IRIS dial
Assignable Dial	Function assigned to the assignable dial

### Battery Status screen

Displays information about the battery and DC IN source.

Detected Battery	Type of battery
Remaining	Remaining capacity (%)
Charge Count	Number of recharges
Capacity	Remaining capacity (Ah)
Voltage	Voltage (V)
Manufacture Date	Date of battery manufacture
Video Light Remaining	Displays the remaining capacity of the video light battery.
Power Source	Power supply source
Supplied Voltage	Supplied power source voltage



## Media Status screen

Displays the remaining capacity and remaining recording time of recording media (XQD memory cards A and B).

Media A information	Displays the media icon when recording media is inserted in slot A.
Media A protection	Displays the lock icon when the recording media inserted in slot A is protected (locked).
<b>Note</b> XQD memory cards cannot be protected using the camcorder.	
Media A remaining capacity meter	Displays the remaining capacity of recording media inserted in slot A expressed as a percentage on a bar graph.
Media A remaining recording time	Displays an estimate of the remaining recording time of the recording media inserted in slot A in units of minutes under the current recording conditions.
Media B information	Displays the media icon when recording media is inserted in slot B.
Media B protection	Displays the lock icon when the recording media inserted in slot B is protected (locked).
<b>Note</b> XQD memory cards cannot be protected using the camcorder.	
Media B remaining capacity meter	Displays the remaining capacity of recording media inserted in slot B expressed as a percentage on a bar graph.
Media B remaining recording time	Displays an estimate of the remaining recording time of the recording media inserted in slot B in units of minutes under the current recording conditions.
SD card information	Displays the media icon when media (for saving configuration data) is inserted in the SD card slot.
SD card protection	Displays the lock icon when the media inserted in the SD card slot (for saving configuration data) is protected (locked).
SD card remaining capacity meter	Displays the remaining capacity of media inserted in the SD card slot (for saving configuration data) expressed as a percentage on a bar graph.

SD card remaining capacity	Displays the remaining capacity of media inserted in the SD card slot (for saving configuration data) expressed in units of GB.
SD card life	Displays the operating life of media in the SD card slot (for saving configuration data) as a percentage.

## Rec Button Settings Screen

Displays the settings of the record START/STOP buttons on the camcorder and handle.

Rec Button	Displays the slots for recording controlled by the recording START/STOP button.
Handle Rec Button	Displays the slots for recording controlled by the recording START/STOP button on the handle.

## Preparation

# Power Supply

You can use a battery pack or AC power supply from an AC adaptor.

For safety, use only the Sony battery packs and AC adaptors listed below.

### Lithium ion battery packs

BP-U30 (supplied)

BP-U60

BP-U60T

BP-U90

### Battery chargers

BC-U1 (supplied)

BC-U2

### AC adaptor (supplied)

MPA-AC1 (USA and Canada model only)

AC-NB12A (except USA and Canada model)

### Caution

Do not store battery packs in locations exposed to direct sunlight, flame, or high temperature.

### Notes

- The camcorder cannot be powered from the BC-U1/BC-U2 battery charger acting as an external power source.
- When operating from a power outlet, use the supplied AC adaptor.

## Using a Battery Pack

To attach a battery pack, plug the battery pack into the attachment (*page 10*) as far as it will go, and then slide it down to lock it into position.

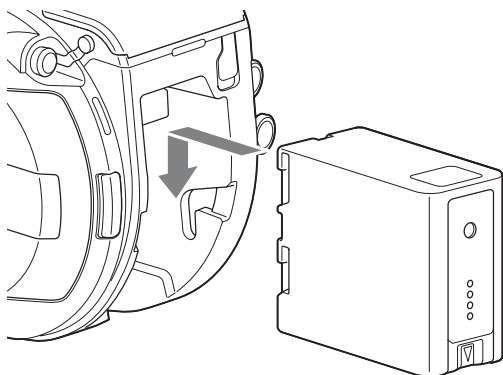

To remove a battery pack, press and hold the BATT RELEASE button (*page 10*), slide the battery pack up and then pull it out of the attachment.

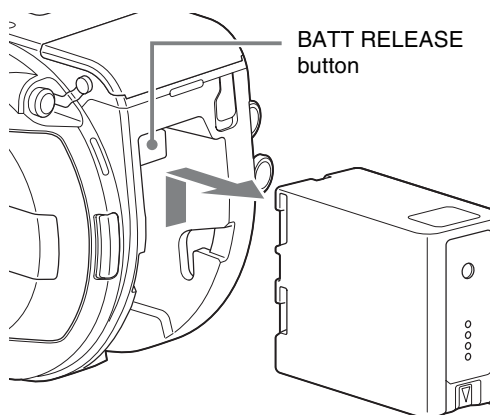

### Notes

- Before attaching a battery pack, charge the battery using the dedicated BC-U1 or BC-U2 battery charger.
- Charging a battery immediately after use while it is still warm may not fully recharge the battery.

## Checking the remaining capacity

When shooting/playing using a battery pack, the remaining battery capacity is displayed in the viewfinder (*page 13*).

Icon	Remaining capacity
	91% to 100%
	71% to 90%
	51% to 70%
	31% to 50%
	11% to 30%
	0% to 10%

The camcorder indicates the remaining capacity by calculating the available time with the battery pack if operation is continued at the current rate of power consumption.

### When using an extension unit

When using the XDCA-FS7 Extension Unit, the battery voltage or the remaining battery capacity is displayed, depending on the battery used.

#### Note

The camcorder battery pack cannot be used when an XDCA-FS7 unit is attached to the camcorder. You must attach a battery pack to the XDCA-FS7 or connect an external power supply.

---

### If the battery pack charge becomes low

If the remaining battery charge falls below a certain level during operation (Low BATT state), a low-battery message appears, the recording indicator starts flashing, and a beep sound will warn you.

If the remaining battery charge falls below the level at which operation cannot continue (BATT Empty state), a battery-empty message appears. Replace with a charged battery pack.

#### Changing the warning levels

The Low BATT level is set to 10% of full battery charge and the BATT Empty level is set to 3% by factory default. You can change the warning level settings using Camera Battery Alarm (*page 87*) in the System menu.

---

### Using AC power

Connecting the camcorder to a power outlet allows use without worrying about the need to recharge the battery pack.

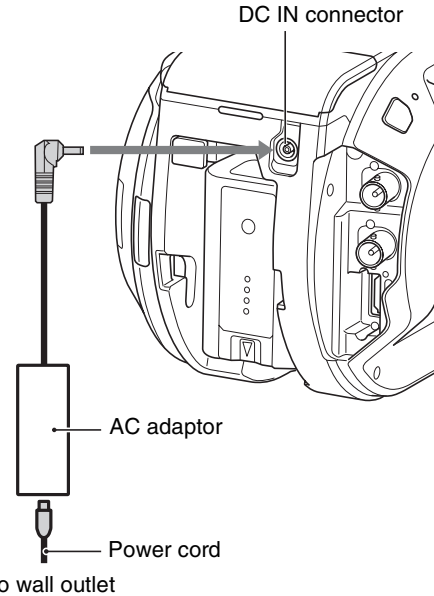

Connect the AC adaptor to the DC IN connector on the camcorder, and connect the power cord (supplied) to a power outlet.

---

### If the output voltage from the AC adaptor becomes low

If the output voltage from the AC adaptor falls below a certain level during operation (DC Low Voltage1 state), a message appears informing you that the AC adaptor output voltage has dropped, the recording indicator starts flashing, and a beep sound is emitted.

If the output voltage from the AC adaptor falls below the level at which operation cannot continue (DC Low Voltage2 state), a message appears informing you that the AC adaptor output voltage is too low.

If this occurs, the AC adaptor may be faulty. Check the AC adaptor, as required.

#### Changing the warning levels

The DC Low Voltage1 level is set to 11.5 V and the DC Low Voltage2 level is set to 11.0 V by factory default. You can change the warning level settings using Camera DC IN Alarm (*page 87*) in the System menu.

---

## AC adaptors

---

- Do not connect and use an AC adaptor in a confined space, such as between a wall and furniture.
- Connect the AC adaptor to the nearest power outlet. If a problem occurs during operation, immediately disconnect the power cord from the outlet.
- Do not short-circuit the metal parts of the plug of the AC adapter. Doing so will cause a malfunction.
- The battery cannot be charged while attached to the camcorder, even if the AC adaptor is connected.

## Attaching Devices

### Attaching the Microphone Holder

#### Notes

- The microphone holder is attached when shipped from the factory.
- Attach/remove the microphone holder while the camcorder is turned off.
- Attach/remove the microphone holder with the mount cap attached so as not to damage the image sensor.

- 1 Insert the microphone holder into the handle.**

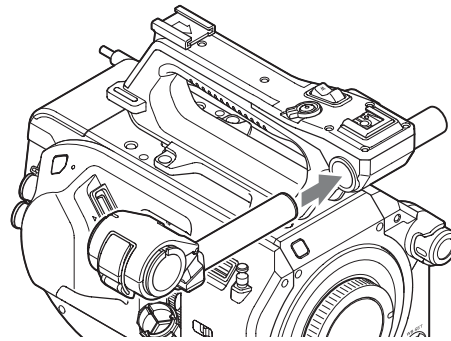

- 2 Insert the stopper into the recess, and tighten the screw to secure the holder.**

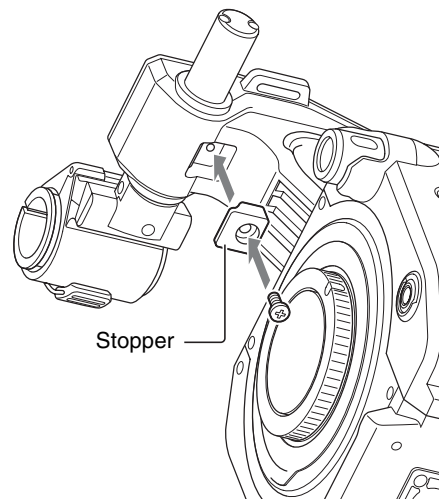

---

## Removing the microphone holder

---

Remove the stopper, and use the reverse procedure of attaching the microphone holder.

## Attaching the Viewfinder

### Note

Attach/remove the viewfinder while the camcorder is turned off.

- 1 Loosen the viewfinder clamp and insert the viewfinder onto the protrusion on the front of the handle.

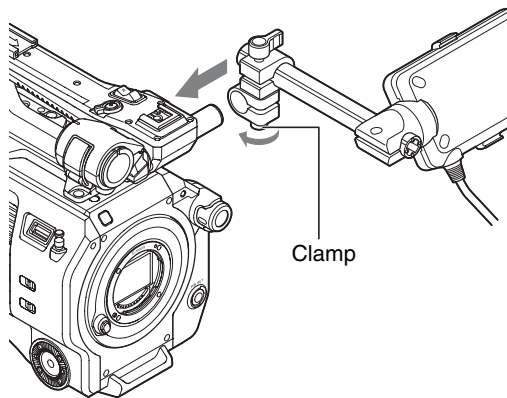

- 2 Adjust the left/right positioning of the viewfinder, tighten the clamp, and then connect the viewfinder cable to the viewfinder connector of the camcorder.

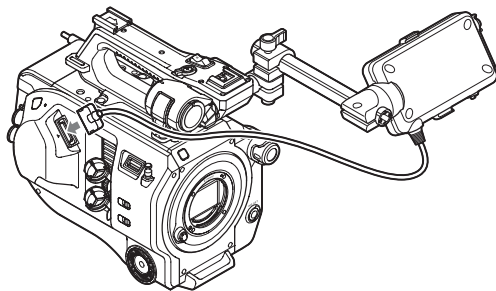

### Note

Check that the viewfinder is securely attached. The viewfinder may fall off during shooting if the clamp is loose.

---

## Adjusting the angle of the viewfinder

---

Tilt the viewfinder up/down to adjust the angle of the viewfinder.

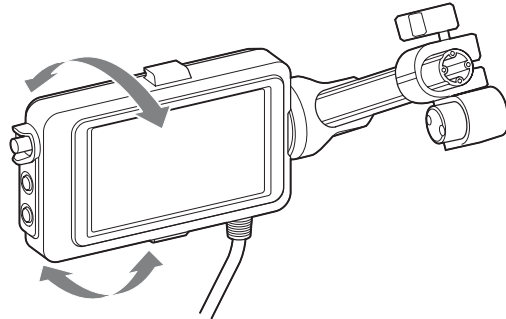

You can adjust the angle so that the viewfinder is facing the subject. Setting the MIRROR switch (page 44) to the B/T flips the left and right sides of the image on the LCD screen, but the image is recorded in the correct orientation.

---

## Adjusting the viewfinder contrast

---

Turn the CONTRAST knob to adjust the contrast.

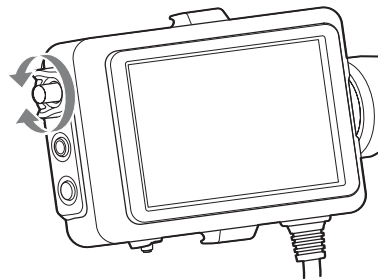

You can adjust the brightness in the viewfinder using VF Setting > Brightness (page 72) in the VF menu.

---

## Removing the viewfinder

---

Loosen the viewfinder clamp, and use the reverse procedure of attaching the viewfinder.

## Attaching the Eyepiece

### Note

Attach/remove the eyepiece while the camcorder is turned off.

- 1 **Attach the metal clips of the eyepiece to the eyepiece attachment hooks on the viewfinder.**

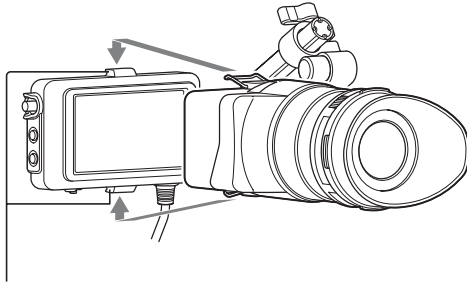

Eyepiece attachment hooks

- 2 **Push the lock plate on the bottom of the eyepiece in the direction of the arrow to lock the eyepiece into position.**

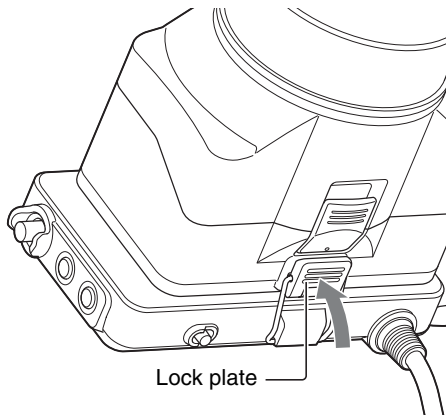

Lock plate

## Opening the eyepiece

Press the button indicated by the arrow.

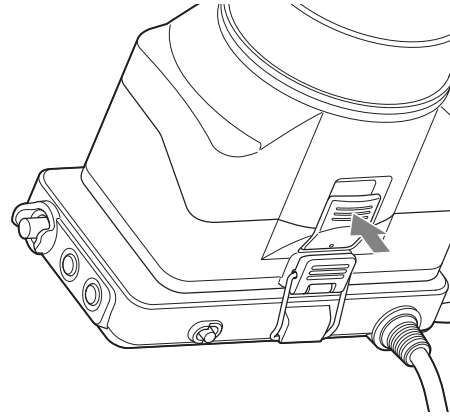

Open the eyepiece upwards when the lock disengages. The viewfinder is directly visible when the eyepiece is opened.

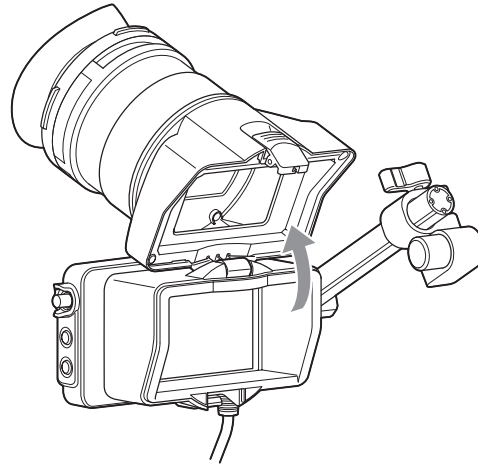

## Removing the eyepiece

Unclip the eyepiece lock, and remove the eyepiece from the viewfinder.

## Attaching a Lens

### Recommended lenses

SELP28135G  
SEL1635Z  
SELP18200

For details about lenses supported by the camcorder, contact your Sony service representative.

### Caution

Do not leave the lens facing the sun. Direct sunlight can enter through the lens, be focused in the camcorder, and may cause a fire.

### Notes

- Attach/remove a lens while the camcorder is turned off.
- A lens is a precision component. Do not place the lens on a surface with the lens mount face down. Attach the supplied lens mount cap.

## Attaching an E-mount lens

- 1 Remove the lens cap and cover from the camcorder and the lens.**

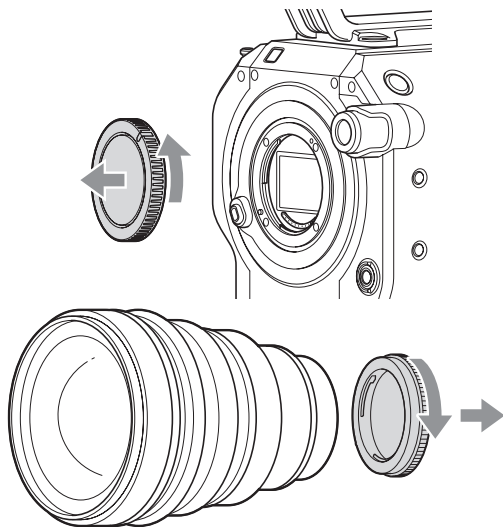

- 2 Align the lens mount mark (white) with the camcorder, carefully insert the lens, and then turn the lens clockwise.**

The lens makes a click sound when it locks into position.

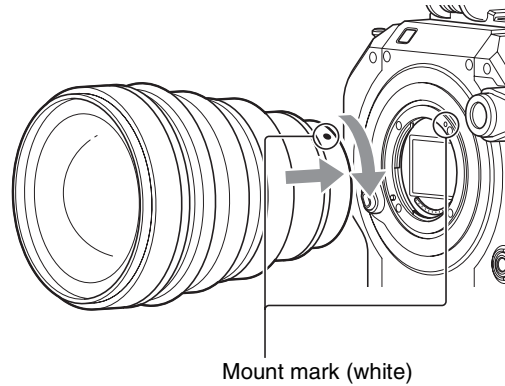

## Attaching an A-mount lens

To use an A-mount lens, attach a lens mount adaptor (option) and then attach the A-mount lens.

### Notes

- When using an A-mount lens, Iris is set to manual.
- When focus is set to AF with an LA-EA2 or LA-EA4 attached, Iris is set to F3.5 or fully open.

## Removing a lens

Remove a lens using the following procedure.

- 1 Press and hold the lens release button and turn the lens counterclockwise.**
- 2 Pull the lens out in the forward direction.**

### Note

If another lens will not be attached immediately, fit the lens mount into the recess part of the lens mount cap and turn clockwise.

## Iris adjustments for lenses with Auto Iris switch

- When the lens Auto Iris is set to AUTO, the iris is adjusted automatically and can also be adjusted manually from the camcorder.
- When the lens Auto Iris is set to MANUAL, the iris can only be adjusted using the lens ring. Iris operation from the camcorder has no effect.

---

## Focus adjustments for lenses with focus switch

---

- When the lens focus switch is set to AF/MF or AF, the focus is adjusted automatically and can also be adjusted manually from the camcorder.
- When the lens focus switch is set to Full MF or MF, the focus can only be adjusted using the lens ring. Focus operation from the camcorder has no effect.

## Attaching the Grip Remote Control

### Note

Attach/remove the grip remote control while the camcorder is turned off.

- 1** Attach the arm to the grip attachment, and tighten the screw.

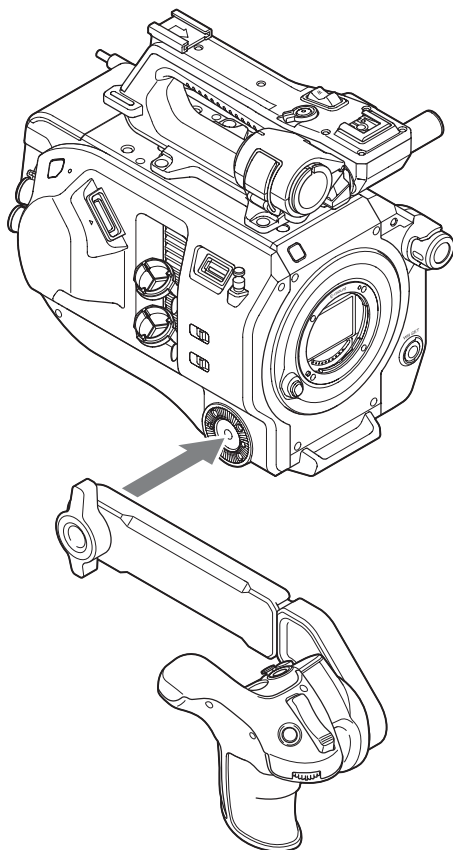

- 2** Connect the grip remote control cable to the REMOTE connector on the camcorder.

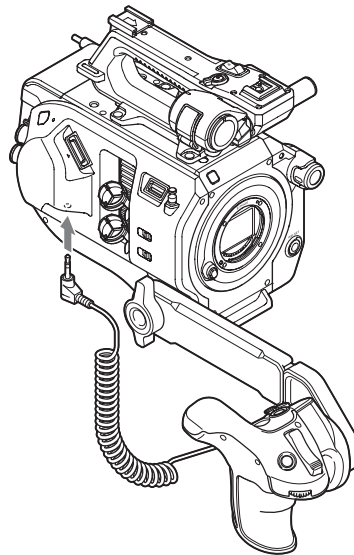

### Notes

- Check that the arm and grip remote control are securely attached. They may fall off during shooting if the screws are loose.
- Do not support the weight of the camcorder by holding just the grip remote control.

---

## Adjusting the position of the grip remote control

---

Adjust the arm angle (①).

Loosen the two screws on the rear side of the arm using a coin or similar object, adjust the arm length (②), and then tighten the two screws.

Press the grip rotation button (page 11) to adjust the angle of the grip remote control (③).

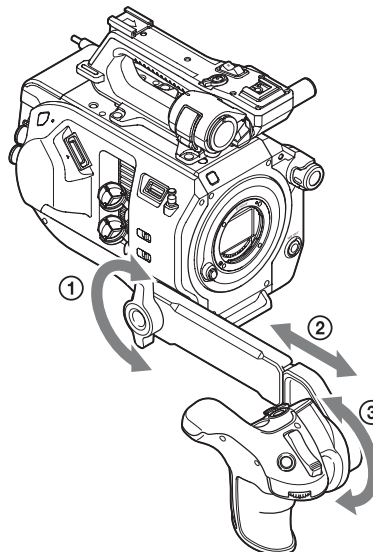



---

## Removing the grip remote control

---

- 1 **Disconnect the grip remote control cable from the REMOTE connector on the camcorder.**
- 2 **Remove the arm from the camcorder.**

## Setting the Clock

The initial settings screen appears in the viewfinder the first time the camcorder is turned on or after the backup battery has become completely discharged.

Set the date and time of the internal clock using this screen.

### Time Zone

Time Zone sets the time difference from UTC (Coordinated Universal Time). Change the setting as required.

---

## Setting the date and time

---

Turn the SEL/SET dial (*page 9*) to select items and settings, then press the SEL/SET dial to apply the settings and start the clock running.

Once the settings screen is closed, you can change the date, time, and time zone settings using Clock Set (*page 86*) in the System menu.

### Notes

- If the clock setting is lost because the backup battery becomes fully discharged due to power being disconnected for an extended period (no battery pack and no DC IN power source), the initial settings screen will be displayed when you next turn the camcorder on.
- While the initial settings screen is displayed, no other operation, except turning the power off, is permitted until you finish the settings on this screen.
- The camcorder has a built-in rechargeable battery for storing the date, time, and other settings even when the camcorder is turned off. For details about the built-in rechargeable battery, *see page 93*.

## Configuring Basic Camcorder Operation

Before shooting, configure the basic operation of the camcorder to suit the application.

### Shooting Mode

You can switch the shooting mode between “Custom” mode to create images flexibly on-site, and “Cine EI” mode (where the camcorder is operated similarly to a film camera, with footage developed in post production).

You can select the mode using Base Setting (page 82) >Shooting Mode in the System menu.

### Color Space

Color Space selects the base color gamut for recorded signals and output signals.

When the shooting mode is set to Custom mode, Color Space is set to “Matrix.”

Matrix: Selects the color gamut using the Matrix setting, similar to conventional video cameras.

When the shooting mode is set to Cine EI mode, Color Space selects the color gamut of the video output with MLUT set to Off.

S-Gamut3.Cine/SLog3: Easy to adjust color gamut for digital cinema (DCIP3).

S-Gamut3/SLog3: Wide color gamut, for compatibility with future standard gamuts, optimized using Sony image distortion correction technology.

You can select the color gamut using Base Setting (page 82) >Color Space in the System menu.

## Using XQD Memory Cards

The camcorder records audio and video on XQD memory cards (available separately) inserted in the card slots.

### About XQD Memory Cards

Use the following Sony XQD memory cards in the camcorder.

For details on operations with media from other manufacturers, refer to the operating instructions for the media or consult the manufacturer’s information.

#### S-series XQD memory cards

#### H-series XQD memory cards

#### N-series XQD memory cards

#### G-series XQD memory cards

The recommended media varies depending on the recording format. For details, contact your Sony sales representative.

The use of memory cards other than Sony XQD memory cards is not guaranteed.

*For details about using XQD memory cards and usage precautions, refer to the operating instructions for the XQD memory card.*

XQD is a trademark of Sony Corporation.

## Inserting an XQD Memory Card

- 1 Press the media cover release button (*page 10*) to open the media cover of the card slot section.
- 2 Insert an XQD memory card with the XQD label facing to the left.  
The access indicator (*page 10*) is lit red, then changes to green if the card is usable.
- 3 Close the media cover.

### Note

The memory card, memory card slot, and image data on the memory card may be damaged if the card is forced into the slot in the incorrect orientation.

## Ejecting XQD Memory Cards

Press the media cover release button (*page 10*) to open the media cover of the card slot section, and lightly press the memory card in to eject the card.

### Notes

- If the camcorder is turned off or the memory card is removed while the memory card is being accessed, the integrity of data on the card cannot be guaranteed. All data recorded on the card may be discarded. Always make sure the access indicator is green or off before turning off the camcorder or removing the memory card.
- When removing an XQD memory card immediately after recording is finished, the XQD memory card may be hot, but this does not indicate a problem.

## Switching Between XQD Memory Cards

When XQD memory cards are loaded in both card slots A and B, you can switch the card used for recording by pressing the SLOT SELECT button (*page 9*).

If a card becomes full during recording, the camcorder automatically switches to the other card.

### Note

The SLOT SELECT button is disabled during playback. The memory cards are not switched even if you press the button. The button is enabled while the thumbnail screen (*page 51*) is displayed.

## Formatting (Initializing) XQD Memory Cards

If an unformatted XQD memory card or an XQD memory card that was formatted in a different specification is inserted, the message “Media Needs to be Formatted” is displayed in the viewfinder.

Format the card using the following procedure.

**Select Format Media (*page 79*) >Media(A) or Media(B) in the Media menu, then select Execute. When a confirmation message appears, select Execute again.**

A message is displayed while formatting is in progress, and the access indicator is lit red. When formatting is completed, a completion message is displayed. Press the SEL/SET dial to dismiss the message.

### If formatting fails

Protected XQD memory cards and memory cards not supported by the camcorder cannot be formatted.

A warning message is displayed. Follow the instructions to replace the card with a supported XQD memory card.

### Note

Formatting a memory card erases all data, including recorded video data and setup files.

## Checking the Remaining Recording Time

When shooting (recording/standby), you can monitor the remaining capacity of the XQD memory card in each slot using the slot A/B media capacity indicators in the viewfinder (*page 13*).

The remaining recording time is calculated from the remaining capacity of the media in each slot and the current video format (recording bit rate), and is displayed in units of minutes.

### Note

A  mark is displayed if the media is protected.

## XQD memory card replacement timing

- When the total remaining recording time on the two memory cards becomes less than 5 minutes, the message “Media Near Full” appears, the recording indicator starts flashing, and a beep sound (headphone output) will warn you. Replace with media that has free space.
- If you continue recording until the total remaining recording time reaches zero, the message changes to “Media Full” and recording stops.

### Note

Up to approximately 600 clips can be recorded on one XQD memory card.

If the number of recorded clips reaches the limit, the remaining recording time indicator becomes “0” and the message “Media Full” is displayed.

## Using a Utility SD Card

You can save camera configuration data for the camcorder on an SD card (available separately). Saved data files can be imported from the SD card.

## Supported SD Cards

**SDHC memory cards\***

**SD memory cards\***

\* Referred to collectively as “SD cards” in this manual.

## Inserting an SD Card

- 1 Press the media cover release button (page 10) to open the media cover of the card slot section.**
- 2 Insert the SD memory card with the SD card label facing to the left.**

The access indicator (page 10) is lit red, then goes off if the card is usable.
- 3 Close the media cover.**

## Ejecting the SD Card

**Press the media cover release button (page 10) to open the media cover of the card slot section, and lightly press the SD card in to eject the card.**

### Notes

- If the camcorder is turned off or the SD card is removed while the SD card is being accessed, the integrity of data on the card cannot be guaranteed. All data recorded on the card may be discarded. Always make sure the access indicator is off before turning off the camcorder or removing the SD card.
- Take caution to prevent the SD card from flying out when inserting/ejecting the card.

## Formatting (Initializing) SD Cards

SD cards must be formatted the first time they are used in the camcorder.

SD cards for use in the camcorder should be formatted using the format function of the camcorder. If a message appears when the SD card is inserted into the camcorder, format the SD card.

**Select Format Media (page 79) >SD Card in the Media menu, then select Execute. When a confirmation message appears, select Execute again.**

A message and progress status are displayed while formatting is in progress, and the access indicator is lit red.

When formatting is completed, a completion message is displayed. Press the SEL/SET dial to dismiss the message.

### Note

Formatting an SD card erases all data on the card. The card cannot be restored.

## Checking the Remaining Capacity

You can check the remaining capacity on an SD card on the Media Status screen (page 17).

### Note

A  mark is displayed if the SD card is protected.

**To use an SD card formatted on the camcorder in the slot of another device**

First, make a backup of the card, then reformat the card in the device to be used.

## Using the XDCA-FS7

You can add functions to the camcorder, such as a V-shoe battery or external sync signal, by attaching an XDCA-FS7 Extension Unit (option) to the camcorder.

## Attaching the XDCA-FS7

### Notes

- The camcorder battery pack cannot be used when an XDCA-FS7 unit is attached to the camcorder. You must attach a battery pack to the XDCA-FS7 or connect an external power supply.
- Attach/remove the XDCA-FS7 while the camcorder is turned off.

- 1 Remove the battery pack (page 18) attached to the camcorder.**
- 2 Remove the cover of the extension unit connector section.**

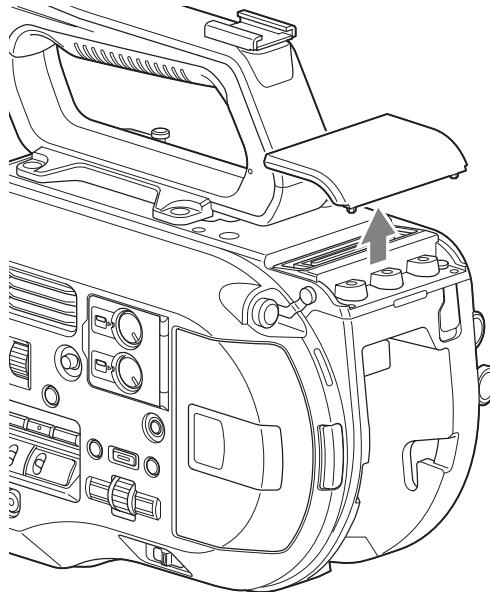

- 3** Align the protrusions of the XDCA-FS7 with the left and right grooves of the camcorder and slide all the way in, then slide the XDCA-FS7 down into the connector section.

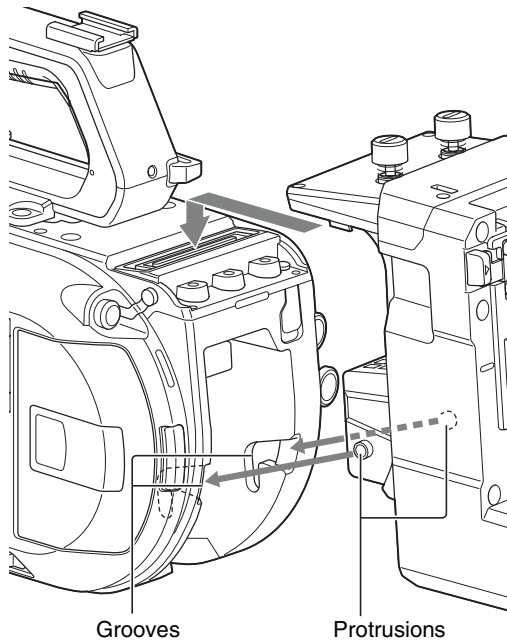

- 4** Tighten the two screws on the top of the XDCA-FS7 to secure the XDCA-FS7.

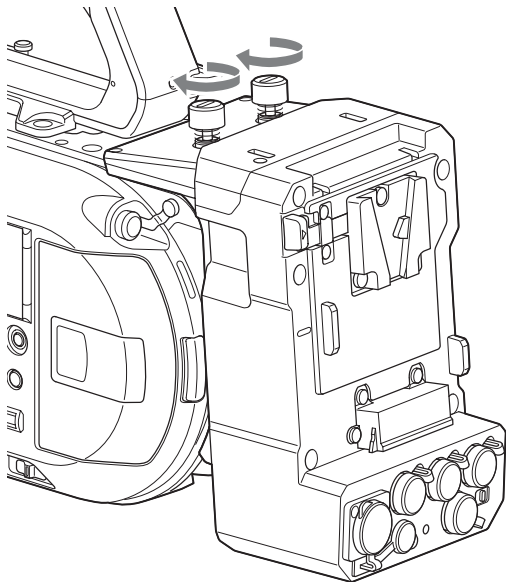

The cover of the extension unit connector section can be inserted into the top of the extension unit.

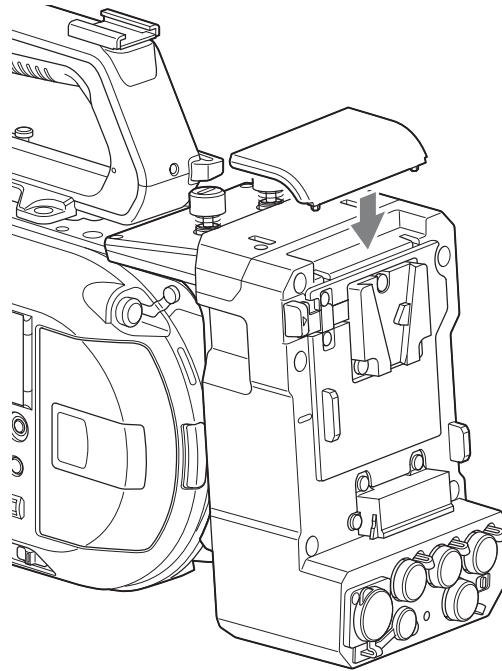

### Removing the XDCA-FS7

Loosen the two screws on the top of the XDCA-FS7, and remove the XDCA-FS7 from the camcorder.

### Attaching the Battery Pack

Insert the battery pack into the battery pack attachment on the XDCA-FS7. The following Sony genuine battery packs are supported.

#### Lithium-ion battery packs

BP-GL65A  
BP-GL95A  
BP-L60S  
BP-L80S  
BP-FL75

## Removing the Battery Pack

Pull the battery pack out from the battery pack attachment on the XDCA-FS7 while holding down the BATT RELEASE button.

## Switching the Timecode Input/Output

You can switch the timecode input/output using the TC IN/OUT switch (*page 12*).

*For details, see page 91.*

## Using an HXR-IFR5 and AXS-R5

You can record RAW video (*page 46*) to an AXS-R5 RAW Recorder (option) using an HXR-IFR5 Interface Unit (option) and an XDCA-FS7. For details about setting up the HXR-IFR5 and AXS-R5, refer to the HXR-IFR5 operation manual.

## Connecting the HXR-IFR5 to the Camcorder

- 1 Attach the XDCA-FS7 to the camcorder (*page 29*).
- 2 Connect the RAW OUT connector of the XDCA-FS7 to the SDI IN (RAW) connector of the HXR-IFR5 using an SDI cable.

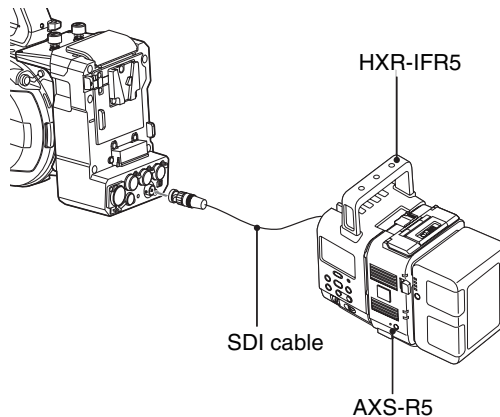

## Removing the HXR-IFR5

Disconnect the SDI cable from the RAW OUT connector of the XDCA-FS7.

## Using the Infrared Remote Control

### When using for the first time

Pull out the insulating sheet from the battery holder when using the supplied infrared remote control for the first time.

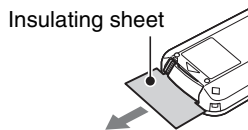

A CR2025 lithium-ion battery is installed in the battery holder at the factory.

### Controlling the camcorder using the remote control

To use remote control, first turn on the camcorder and then enable remote control operation.

Use the setup menu to enable/disable the remote control function.

#### To enable using the menu

Press the MENU button to switch the camcorder to menu mode, then set IR Remote (*page 87*) in the System menu to On.

#### Notes

- Point the remote control at the remote control receiver sensor on the camcorder.
- Set up the camcorder so that the remote control receiver sensor is not exposed to direct sunlight or strong light from other sources. Strong light can prevent proper remote control operation.
- Other video decks may operate by mistake when using the supplied remote control to operate the camcorder. In this case, switch the remote control mode switch on the video deck to DVD2, or shield the remote control receiver sensor using black paper.

### Changing the battery of the remote control

The remote control uses a standard CR2025 battery.

Do not use a battery other than the CR2025.

- 1 Push the tab in, and remove the battery holder by placing a fingernail in the groove.**
- 2 Insert a new battery with the + terminal facing up.**
- 3 Insert the battery holder until it clicks into place.**

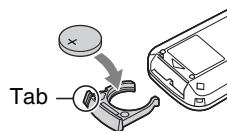

#### Caution

Do not store battery packs in locations exposed to direct sunlight, flame, or high temperature.

#### Note

Replacing the battery with a non-specified battery may cause device failure. Always replace with the specified battery.

Dispose of used batteries in accordance with federal and local laws.



# Using Wi-Fi Remote Control

You can operate the camcorder from a web browser by connecting a smartphone, tablet, or other device that supports a web browser to the camcorder using a wireless LAN connection. This function is called Wi-Fi remote control. This function is useful when operating the camcorder from a remote location, for example, when the camcorder is mounted on a crane. For details of the Wi-Fi remote control setup procedure, see *page 50*.

## Wi-Fi Remote screen (smartphone)

### Main screen

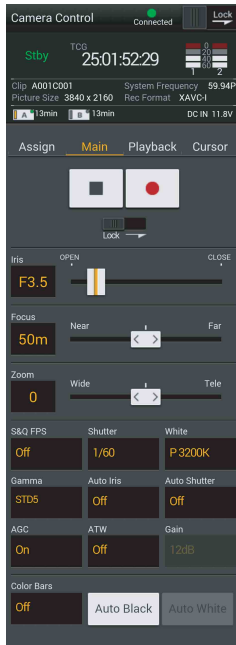

- Settings  
S&Q FPS, Shutter, White, Sensitivity/Gain/Exposure Index, Gamma, MLUT, Color Bars, Auto Black, Auto White, Rec Start/Stop, Lock, Iris, Focus, Zoom, Auto Iris, Auto Shutter, AGC, ATW

### Playback screen

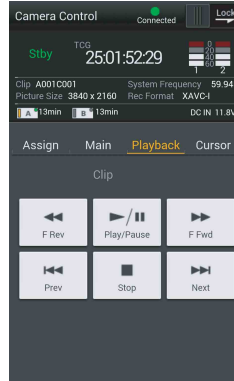

- Status
- Playback buttons  
Play/Pause, Stop, F Fwd, F Rev, Next, Prev

### Cursor screen

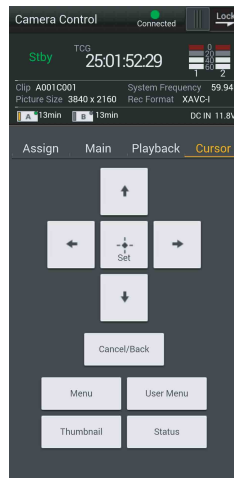

- Status
- Cursor buttons  
Up, Down, Left, Right, Set, Cancel/Back, Menu, Status, Thumbnail, User Menu

### Assign screen

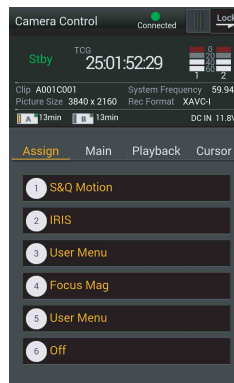

- Status
- Assignable buttons  
Assignable buttons 1 to 6

## Wi-Fi Remote screen (tablet)

### Main screen

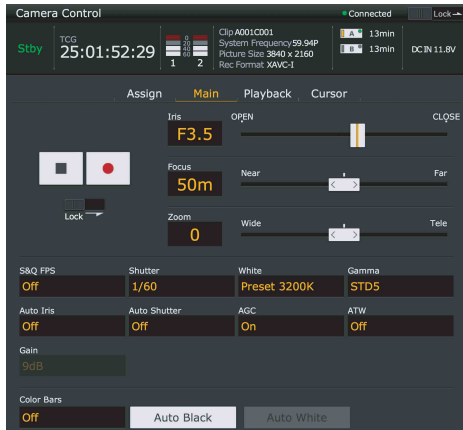

- Settings  
S&Q FPS, Shutter, White, Sensitivity/Gain/Exposure Index, Gamma, MLUT, Color Bars, Auto Black, Auto White, Rec Start/Stop, Lock, Iris, Focus, Zoom, Auto Iris, Auto Shutter, AGC, ATW

### Playback screen

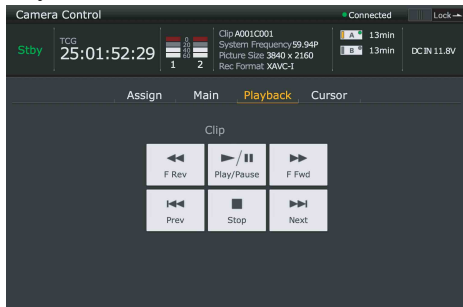

- Status
- Playback button  
Play/Pause, Stop, F Fwd, F Rev, Next, Prev

## Cursor screen

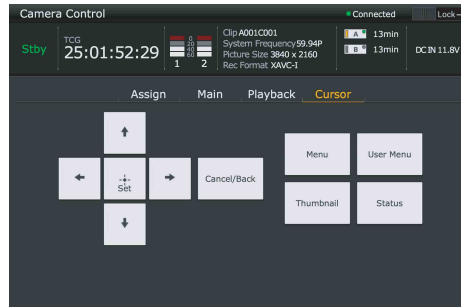

- Status
- Cursor buttons  
Up, Down, Left, Right, Set, Cancel/Back, Menu, Status, Thumbnail, User Menu

## Assign screen

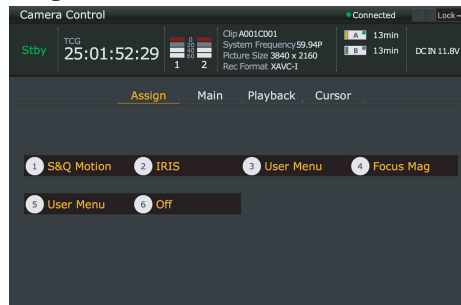

- Status
- Assignable buttons  
Assignable buttons 1 to 6

## Shooting

# Basic Operation Procedure

Basic shooting is conducted using the following procedure.

**1 Attach the necessary devices, and check that power is being supplied.**

**2 Insert the memory card(s).**

**3 Set the POWER switch to the ON position.**

The camera image appears in the viewfinder.

**4 Press the record button (page 7).**

The recording indicator turns on, and the camcorder starts recording.

**5 To stop recording, press the record button again.**

Recording stops, and the camcorder switches to STBY (standby) mode.

## Shooting (Full Auto mode)

Press the FULL AUTO button, turning the button indicator on.

The auto iris (compatible lenses only), AGC, auto shutter, ATW (auto tracing white balance) functions are enabled to control the brightness and white balance automatically (full auto mode). To control each function manually, turn Full Auto mode off.

## Recording continuously when changing memory cards (Relay Rec)

When memory cards are inserted in both slots A and B, recording automatically switches to the second memory card just before the remaining capacity on the first card is reduced to zero.

### Notes

- Do not eject a memory card while recording to it is in progress. Only change memory cards in slots for which the slot access indicator is off.
- When the remaining capacity on the memory card being recorded becomes less than one minute and a recordable memory card is inserted in the other slot, a “Will Switch Slots Soon” message appears. The message disappears after switching memory card slots.

- Relay recording may not operate if recording is started when the remaining memory card capacity is less than one minute. For correct relay recording, check that the remaining memory card capacity is more than one minute before starting recording.
- Video created using the camcorder relay recording function cannot be played back seamlessly on the camcorder.
- To combine video created using the camcorder relay recording function, use Content Browser software.

## Recording to memory cards A and B simultaneously (Simul Rec)

You can simultaneously record using both memory cards A and B.

**Set Simul Rec >Setting in the Recording menu to “On.”**

### Note

Simultaneous recording is not supported in Slow & Quick Motion mode (page 77) or Picture Cache recording mode (page 77). Also, simultaneous recording is not supported for the following recording formats (page 82).

### NTSC Area

#### XAVC-I

3840 × 2160 59.94P, 3840 × 2160 29.97P,  
3840 × 2160 23.98P, 1920 × 1080 59.94P

#### XAVC-L

3840 × 2160 59.94P, 3840 × 2160 29.97P,  
3840 × 2160 23.98P

#### RAW (with XDCA-FS7, HXR-IFR5, and AXS-R5 connected)

4096 × 2160 59.94P, 4096 × 2160 29.97P,  
4096 × 2160 23.98P, 2160 × 1080 59.94P,  
2160 × 1080 29.97P, 2160 × 1080 23.98P

#### RAW & XAVC-I (with XDCA-FS7, HXR-IFR5, and AXS-R5 connected)

4096 × 2160 59.94P, 2160 × 1080 59.94P

### PAL Area

#### XAVC-I

3840 × 2160 50P, 3840 × 2160 25P,  
1920 × 1080 50P

#### XAVC-L

3840 × 2160 50P, 3840 × 2160 25P

#### RAW (with XDCA-FS7, HXR-IFR5, and AXS-R5 connected)

4096 × 2160 50P, 4096 × 2160 25P,  
2160 × 1080 50P, 2160 × 1080 25P

#### RAW & XAVC-I (with XDCA-FS7, HXR-IFR5, and AXS-R5 connected)

4096 × 2160 50P, 2160 × 1080 50P

---

## Changing the settings of the record buttons on the camcorder and handle

---

When the simultaneous recording (Simul Rec) is enabled, you can start/stop recording to each memory card independently using the record START/STOP buttons on the camcorder and the handle.

By factory default, both buttons are set to start/stop simultaneous recording to both memory cards A and B.

- “Rec Button [SlotA SlotB] Handle Rec Button [SlotA SlotB]”

### To change the setting

#### Select Simul Rec >Rec Button Set in the Recording menu.

Rec Button Set	Buttons and memory cards
“Rec Button [SlotA SlotB] Handle Rec Button [SlotA SlotB]”	Starts/stops simultaneously recording to memory cards A and B using either button.
“Rec Button [SlotA] Handle Rec Button [SlotB]”	The record START/STOP button starts/stops recording to memory card A, and the record START/STOP button on the handle starts/stops recording to memory card B.
“Rec Button [SlotB] Handle Rec Button [SlotA]”	The record START/STOP button starts/stops recording to memory card B, and the record START/STOP button on the handle starts/stops recording to memory card A.

---

## Adjusting the Focus Automatically

A lens that supports auto focus is required. Set the FOCUS switch (*page 9*) on the camcorder to the “AUTO” position. If the lens is fitted with a focus selector switch, set the switch to the “AF/MF” or “AF” position. If the switch is set to the “Full MF” or “MF” position, lens focusing cannot be operated from the camcorder (*page 24*).

---

## Temporarily stopping auto focus (Focus Hold)

---

Press the PUSH AUTO FOCUS button (*page 9*) when in auto focus mode to override auto focus. This is useful, for example, when something crosses in front of the subject that you do not want to focus on, or when auto focus is lost.

## Adjusting the Focus Manually

To adjust the focus manually, set the FOCUS switch (*page 9*) to “MAN.”

This allows you to adjust the focus manually according to the shooting conditions.

Manual focusing is useful for the following types of subjects.

- Subjects on the far side of a window covered in water droplets
- Subjects with low contrast against the background
- Subjects further away than nearby subjects

---

## Adjusting focus rapidly using manual focus (Push Auto Focus)

---

Position the subject that you want to adjust focus for in the center of the image, then press the PUSH AUTO FOCUS button (*page 9*).

The focus returns to the previous setting when you release the button.

This is useful when you want to quickly focus on a subject before starting to shoot.

### Notes

- The Push Auto Focus function does not operate if the lens is set for manual focusing.
- During Push Auto Focus operation when using an LA-EA2/4, Full Auto mode is On.

### Focus indicator

Indicates the focus state.

- (On): Subject is in focus.
- (Flashing): Subject is out of focus. Since focusing is not automatic, change the composition and focus settings to achieve focus.

---

## Focusing using magnified view (Focus Magnifier)

---

By factory default, the Focus Magnifier x4/x8 function is assigned to the ASSIGN4 button on the grip remote control (*page 42*).

### Press the ASSIGN4 button.

The focus magnifier screen appears with the center magnified by approximately four times. Press the button again to increase the magnification to approximately eight times. This function is useful for checking the focus. Press the button again to return to the normal screen.

#### Notes

- The recorded image or SDI/HDMI output image is not magnified when the focus is magnified.
- During focus magnification, the STATUS CHECK button and menu buttons have no effect.

## Monitoring Audio

You can monitor the audio that is being recorded using headphones.

Connecting a set of headphones to the headphone connector (*page 10*) enables you to monitor the audio being recorded. You can also monitor the playback audio (*page 52*) using the built-in speaker (*page 10*) or headphones.

You can select the audio channel to monitor and adjust the volume using Audio Output (*page 69*) in the Audio menu.

## Switching Between XQD Memory Cards

When two XQD memory cards are inserted, press the SLOT SELECT button (*page 9*) to switch cards.

#### Note

You cannot switch between memory cards during playback mode. Also, continuous playback of a clip spanning media in slot A and slot B is not supported.

### Clips (recorded data)

When you stop recording, the video, audio, and accompanying data from the start to the end of the recording are saved as a single “clip” on an XQD memory card.

### Clip names

Each clip recorded by the camcorder is automatically assigned a clip name comprising the word “Clip” and a 4-digit number. The 4-digit number automatically increments with each recording.

You can change the “Clip” prefix using Clip in the Media menu.

### Maximum clip duration

The maximum duration of a clip varies depending on the recording format.

The maximum duration of continuous recording is the same as the maximum duration of a clip.

When the recording time reaches the maximum duration, recording stops.

## Changing Basic Settings

You can change the settings based on the video application or recording conditions.

### Selecting the Recording Format

The formats available for selection vary depending on the Country (region of use) and Codec settings.

Select a format using Rec Format >Video Format in the System menu.

### Adjusting the Brightness

You can adjust the brightness by adjusting the iris, gain, shutter speed, and by adjusting the light level using ND filters.

When adjusting the brightness without using ND filters, turn Full Auto mode (*page 35*) off.

You can adjust the brightness control target level in the setup menu.

#### Adjusting the control target level

Set the level using Auto Exposure (*page 59*) >Level in the Camera menu.

#### Note

The brightness cannot be adjusted automatically in Cine EI mode.

### Adjusting the iris automatically

This function adjusts the brightness according to the subject. A lens that supports auto iris is required.

- 1 If a lens with Auto Iris switch is attached, set the switch to AUTO.**
- 2 Press the IRIS button (*page 42*) to turn Auto Iris on.**

The setting toggles between on and off each time the IRIS button is pressed.

### Adjusting the iris manually

**Press the IRIS button to turn Auto Iris off, then adjust using the IRIS dial.**

You can also assign the IRIS function to an assignable dial (*page 42*).

#### Turning auto iris on temporarily

Press and hold the PUSH AUTO IRIS button to turn auto iris on temporarily.

The iris returns to the previous setting when you release the button.

#### Note

When the Auto Iris switch of the lens is set to "MANUAL," the Auto Iris and Push Auto Iris functions on the camcorder have no effect. Manual iris adjustments on the camcorder also have no effect.

### Adjusting the gain automatically

Press the ISO/Gain button (*page 9*) to turn AGC on.

Or select Auto Exposure (*page 59*) >AGC in the Camera menu and set to "On."

### Adjusting the gain manually

You can control the gain when you want to adjust the exposure while using a fixed iris setting or when you want to prevent the gain increasing due to AGC.

- 1 Press the ISO/Gain button (*page 9*) to turn AGC off.**
- 2 Set the GAIN switch (*page 9*) to H, M, or L.**

### Controlling the gain (fine adjustment)

Turn the IRIS dial, or the assignable dial assigned with the ISO/Gain/EI function, to adjust the gain value set by the GAIN switch.

This is useful when you want to adjust the exposure by one step without changing the depth of field.

The adjusted gain value is canceled by switching the GAIN switch or by turning AGC on.

---

## Shooting using auto shutter

---

This function adjusts the shutter speed automatically in response to the image brightness.

### Press the SHUTTER button (page 9).

If the settings screen was displayed, press the button again.

Or set Auto Exposure (page 59) >Auto Shutter in the Camera menu to On.

---

## Shooting with a fixed shutter

---

You can shoot with a set shutter speed.

Press the SHUTTER button to display a screen with the supported shutter values, and select and set a value using the SEL/SET dial. If you press the SHUTTER button again instead of the SEL/SET dial, auto shutter is enabled.

### Setting in the Camera menu

Select Shutter (page 61) in the Camera menu and set the shutter mode and speed.

---

## Adjusting the light level (ND filter)

---

In conditions where the lighting is too bright, you can set the appropriate brightness by changing the ND filter.

Turn the ND FILTER switch (page 9) to select Clear → 1/4 → 1/16 → 1/64 → Clear in sequence.

## Adjusting for Natural Colors (White Balance)

You can select the adjustment mode to suit the shooting conditions.

---

## ATW (auto tracing white balance)

---

This function adjusts the white balance automatically to an appropriate level.

The white balance is automatically adjusted when the color temperature of the light source changes. Pressing the WHT BAL button (page 9) switches ATW on/off.

You can select the speed of adjustment (five steps) using White >ATW Speed (page 63) in the Paint menu.

You can freeze the current white balance setting by assigning the ATW Hold function to an assignable button (page 42), and pressing the assignable button to temporarily pause ATW mode.

### Notes

- ATW does not operate in Cine EI mode. Also, when ATW mode is set to Preset, the available color temperature options are 3200K, 4300K, and 5500K only, and the auto white balance function does not operate.
- It may not be possible to adjust to the appropriate colors using ATW, depending on the lighting and subject conditions.  
Examples:
  - When a single color dominates the subject, such as sky, sea, ground, or flowers.
  - When the color temperature is extremely high or extremely low.  
If the appropriate effect cannot be obtained because the ATW auto tracking speed is slow or for other reasons, run auto white balance.

---

## Adjusting the white balance manually

---

- 1 Turn Full Auto mode (page 35) off.**
- 2 When white balance is set to ATW mode, press the WHT BAL button (page 9) to set manual mode.**

### 3 Select B, A, or PRESET using the WHT BAL switch (page 9).

B: Memory B mode \*

A: Memory A mode

PRESET: Preset mode

\* B can be assigned to ATW ON.

#### Preset mode

This mode adjusts the color temperature to a preset value (factory default is 3200K).

#### Memory A/Memory B mode

This mode adjusts the white balance to the setting saved in memory A or B, respectively.

---

### Running auto white balance

---

#### 1 Press the ISO/Gain button (page 9) to turn AGC on.

Or select Auto Exposure (page 59) >AGC in the Camera menu and set to “On.”

#### 2 To save an adjustment value in memory, select memory A mode or memory B mode.

#### 3 Place white paper (or other object) in a location with the same lighting source and conditions as the subject, then zoom in on the paper to show white on the screen.

#### 4 Adjust the brightness.

Adjust the iris using the procedure in “Adjusting the iris manually” (page 38).

#### 5 Press the WB SET button (page 7).

If auto white balance is set in memory mode, the adjustment value is saved in the memory (A or B) selected in step 2.

If auto white balance is set in ATW mode, the white balance adjustment returns to the ATW mode white balance when adjustment ends.

#### Notes

- You can enable auto white balance when in preset mode using White >AWB Enable<P> in the Paint menu. The setting is disabled again when the camcorder is turned off.
- If the adjustment is not successful, an error message is displayed on the screen for about three seconds. If the error message persists after repeated attempts to set white balance, contact your Sony service representative.

## Setting the Audio to Record

You can specify the audio to be recorded using the input connectors, switches, and dials of the camcorder.

#### External audio input connectors and selector switches

INPUT1 connector (page 10)

INPUT2 connector (page 10)

INPUT1 switch (LINE/MIC/MIC+48V) (page 7)

INPUT2 switch (LINE/MIC/MIC+48V) (page 7)

#### Switches for setting the audio level

CH1 (AUTO/MAN) switch (page 9)

CH2 (AUTO/MAN) switch (page 9)

AUDIO LEVEL (CH1) dial (page 9)

AUDIO LEVEL (CH2) dial (page 9)

---

### Selecting the audio input device

---

#### 1 Select the audio input connector.

Select the audio input using Audio Input >CH1 Input Select or CH2 Input Select in the Audio menu.

Set to “INPUT1” or “INPUT2” to correspond to the connector for the connected device. If using a shoe microphone, specify “Shoe 1” or “Shoe 2” in the same way.

#### 2 Select the input audio source.

Set the INPUT1/INPUT2 (LINE/MIC/MIC+48V) switches to the devices connected to the INPUT1/INPUT2 connectors, respectively.

Connected device	Switch position
External audio source (e.g. LINE mixer)	LINE
Dynamic microphone, battery-operated microphone	MIC
+48 V phantom power feed microphone	MIC+48V

- Selecting “MIC+48V” and connecting a microphone that is not compatible with a +48 V source may damage the connected device. Check the setting before connecting the device.
- If noise is a concern on connectors with no device connected, set the corresponding INPUT1/INPUT2 (LINE/MIC/MIC+48V) switches to “LINE.”



---

## Adjusting the audio recording level automatically

---

Set the CH1/CH2 (AUTO/MAN) switches for the channels to adjust automatically to “AUTO.”

---

## Adjusting the audio recording level manually

---

Use the following procedure to adjust the audio recording level.

- 1 Set the CH1/CH2 (AUTO/MAN) switches for the channels to adjust manually to “MAN.”**
- 2 During shooting or standby, turn the AUDIO LEVEL (CH1)/(CH2) dials of the corresponding channels to adjust the audio level.**

You can also adjust the recording level using the assignable dial (*page 42*) if assigned with the Audio Input Level function, or from the setup menu.

### Notes

- If Audio Input >CH1 Level and CH2 Level in the Audio menu are both set to “Side,” Audio Input Level in the menu is disabled as there is no target for the Audio Input Level setting. In this case, an assignable dial with Audio Input Level assigned also cannot be used to adjust the audio level.
- If Audio Input >CH1 Level or CH2 Level in the Audio menu is set to “Lvl + Side,” the adjustment value is the product of the Audio Input Level setting and the level set by the AUDIO LEVEL dial. If either level is set to the minimum value, the audio is muted. If both levels are set to the maximum value, the maximum level is selected.

## Specifying Time Data

---

### Setting the timecode

---

Set the timecode to record using Timecode (*page 76*) in the TC/UB menu.

---

### Displaying time data

---

Press the DISPLAY button to display time data on the screen (*page 14*).

Set the timecode to display using TC Display (*page 76*) >Display Select in the TC/UB menu. Pressing an assignable button (*page 42*) with DURATION/TC/U-BIT assigned will switch the display between the timecode, user bits, and duration in sequence.

## Useful Functions

### Assignable Buttons/Dials

There are six assignable buttons (*page 9*, *page 11*) on the camcorder to which you can assign functions.

You can also assign functions to the IRIS dial (*page 9*) on the camcorder and the assignable dial (*page 11*) on the grip remote control.

### Changing the button function

Use Assignable Button (*page 83*) in the System menu.

You can view the assigned functions on the Assignable Button Status screen (*page 16*).

**The following functions are assigned to each assignable button by factory default.**

Button 1	S&Q Motion
Button 2	IRIS
Button 3	User Menu
Button 4	Focus Magnifier x4/x8
Button 5	User Menu
Button 6	Off

### Assignable functions

- Off
- Marker
- Zebra
- Peaking
- Video Signal Monitor
- DURATION/TC/U-BIT
- Focus Magnifier x4/x8
- Focus Magnifier x4
- Focus Magnifier x8
- Push AF/Focus Hold
- VF Mode
- IRIS
- AGC
- SHUTTER
- Auto Exposure Level
- Push Auto Iris
- Push AGC
- Spotlight
- Backlight
- ATW
- ATW Hold
- SteadyShot

- Color Bars
- User Menu
- Rec Lamp
- S&Q Motion
- Picture Cache Rec
- Rec Review
- Thumbnail
- Shot Mark1
- Shot Mark2
- Clip Flag OK
- Clip Flag NG
- Clip Flag Keep
- High/Low Key

### Changing the dial function

Use Assignable Dial (*page 85*) in the System menu.

You can view the assigned functions on the Assignable Button Status screen (*page 16*).

IRIS is assigned by factory default.

### Assignable functions

- Off
- IRIS
- ISO/GAIN/EI
- Focus
- Audio Input Level

## Slow & Quick Motion

When the video format (*page 82*) is set to one of the following values, you can specify a different value for the recording frame rate and playback frame rate.

### NTSC Area

#### XAVC-I

3840 × 2160 59.94P, 3840 × 2160 29.97P,  
3840 × 2160 23.98P, 1920 × 1080 59.94P,  
1920 × 1080 29.97P, 1920 × 1080 23.98P

#### XAVC-L

3840 × 2160 59.94P, 3840 × 2160 29.97P,  
3840 × 2160 23.98P, 1920 × 1080 59.94P 50,  
1920 × 1080 59.94P 35, 1920 × 1080 29.97P  
50, 1920 × 1080 29.97P 35, 1920 × 1080  
23.98P 50, 1920 × 1080 23.98P 35

### PAL Area

#### XAVC-I

3840 × 2160 50P, 3840 × 2160 25P,  
1920 × 1080 50P, 1920 × 1080 25P

#### XAVC-L

3840 × 2160 50P, 3840 × 2160 25P,  
1920 × 1080 50P 50, 1920 × 1080 50P 35,  
1920 × 1080 25P 50, 1920 × 1080 25P 35

### Notes

- Slow & Quick Motion cannot be set during recording, playback, or while the thumbnail screen is displayed.
- Audio recording is not supported in Slow & Quick Motion mode.
- The auto focus function is disabled in Slow & Quick Motion mode.
- The following conditions apply when shooting at frame rates higher than 60 fps.
  - The focus assist indicator, depth of field indicator, focus position indicator, iris position indicator, and zoom position indicator are all turned off.

### NTSC Area

Format	Resolution	Frame rate	High frame rate
XAVC-I	2160	1 to 60 fps	– (59.94P, 29.97P, 23.98P)
	1080	1 to 60 fps	72/75/80/90/96/ 100/110/120/125/ 135/144/150/160/ 168/175/180 fps (59.94P, 29.97P, 23.98P)
XAVC-L	2160	1 to 60 fps	– (59.94P, 29.97P, 23.98P)
	1080	1 to 60 fps	72/75/80/90/96/ 100/110/120 fps (59.94P 50, 59.94P 35, 29.97P 50, 29.97P 35, 23.98P 50, 23.98P 35)

### PAL Area

Format	Resolution	Frame rate	High frame rate
XAVC-I	2160	1 to 60 fps	– (59P, 25P)
	1080	1 to 60 fps	72/75/80/90/96/ 100/110/120/125/ 135/144/150 fps (59P, 25P)
XAVC-L	2160	1 to 60 fps	– (59P, 25P)
	1080	1 to 60 fps	72/75/80/90/96/ 100/110/120 fps (50P 50, 50P 35, 25P 50, 25P 35)

## Picture Cache Recording (Picture Cache Rec)

The picture cache recording function allows you to capture video retroactively when you start recording and then record it to XQD memory cards by maintaining an internal cache memory of a specified duration when shooting. The picture cache recording time is set using Picture Cache Rec >Cache Rec Time (*page 77*) in the Recording menu.

### Notes

- Picture Cache Rec cannot be on at the same time as Frame Rec, Interval Rec, or Slow & Quick Motion. When Picture Cache Rec is turned on, these other recording modes are forcibly turned off.
- Picture Cache Rec mode cannot be selected while recording or Rec Review is in progress.

- When Picture Cache Rec is on, the timecode is recorded in Free Run mode regardless of the setting in the TC/UB menu (page 76).

## Configuring before shooting

Configure Picture Cache Rec (page 77) in the Recording menu before shooting.

You can also assign the Picture Cache Rec function to an assignable button (page 42) and switch Picture Cache Rec on/off using the button. When configured, the ● (green) indicator appears in the viewfinder (page 13).

## Picture cache recording

When you press the record button, recording starts and video is written to XQD memory cards starting from the video stored in the cache memory.

### To cancel Picture Cache Rec

Turn off Picture Cache Rec >Setting in the Recording menu or press an assignable button assigned with the Picture Cache Rec function.

#### Notes

- Changing the recording format clears the video in cache memory stored up to that point, and starts caching new video. Consequently, picture cache recording of pictures before changing format is not possible, even if you start recording immediately after changing format.
- If Picture Cache Rec is turned on/off immediately after inserting an XQD memory card, cache data may not be recorded on the card.
- Video is stored in cache memory when the cache recording function is turned on. Video prior to the function being turned on is not cached.
- Video is not stored in cache memory while an XQD memory card is being accessed, such as during playback, Rec Review, or thumbnail screen display. Picture cache recording of video during that interval is not possible.
- You can change the cache recording time setting using the menu while recording is in progress, but the new value does not come into effect until after recording ends.

## Reviewing a Recording (Rec Review)

You can check the video of the most recently recorded clip on the screen.

**When recording is stopped, press the assignable button (page 42) with Rec Review assigned.**

The clip is played to the end, Rec Review ends, and the camcorder returns to STBY (standby) mode.

### To stop Rec Review

Press the assignable button with Rec Review assigned.

#### Note

Rec Review is not supported if the video format is changed after recording a clip.

## Self Portrait Mode

You can flip the image in the viewfinder (page 11) vertically or horizontally/vertically using the MIRROR switch.

This allows you to turn the viewfinder 180° toward the lens.

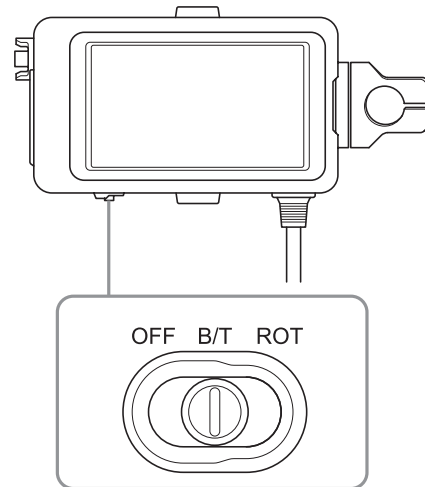

## OFF

The image is not inverted.

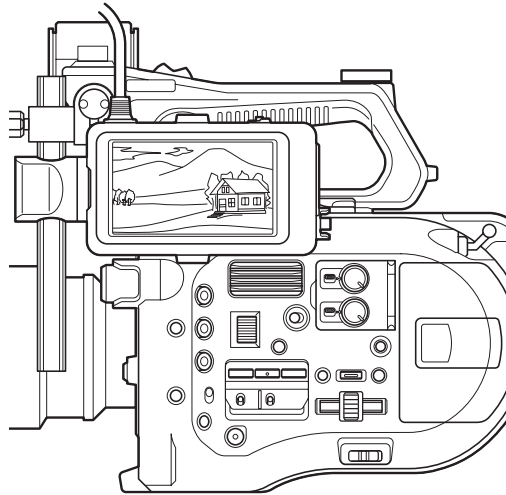
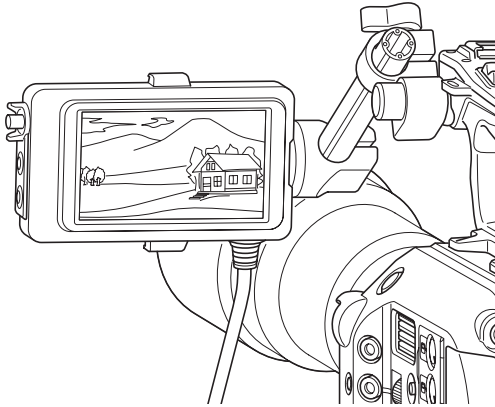

## B/T

The image is flipped vertically.  
The information display is flipped vertically and horizontally.

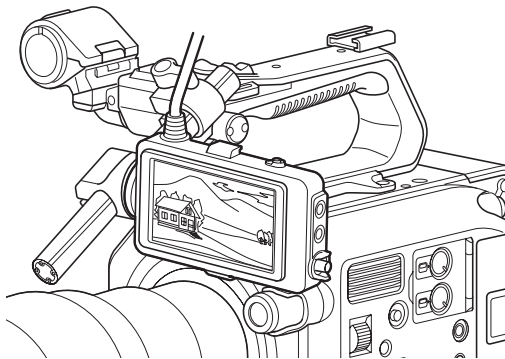

## Note

The B/T and ROT view are displayed in the viewfinder only. The output video and recorded video remain unaffected.

## Displaying Peaking

You can turn peaking on/off by pressing the PEAKING button on the viewfinder (*page 11*). You can turn peaking on/off and set the peaking type and peaking frequency using Peaking (*page 72*) in the VF menu.

## ROT

The image is flipped vertically and horizontally.  
The information display is also flipped vertically and horizontally.

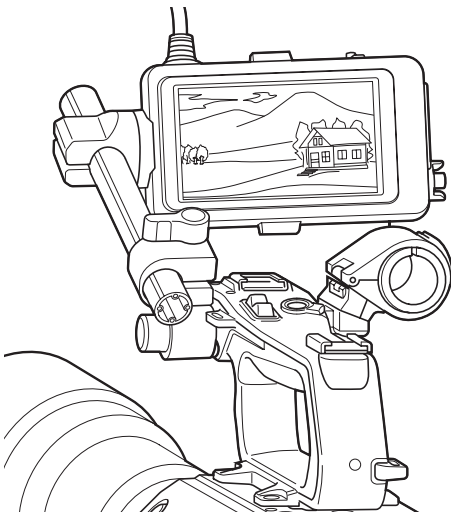

## Displaying Zebra

You can turn zebra pattern display on/off by pressing the ZEBRA button on the viewfinder (*page 11*). You can turn zebra pattern display on/off, and set the zebra pattern type and display level using Zebra (*page 72*) in the VF menu.





## Obtaining Location Information (GPS)

### Set GPS to “On” in the System menu.

 is displayed when the camcorder is seeking GPS satellites. When positioning is established, location information is recorded when shooting video.

#### Notes

- The GPS setting in the System menu cannot be turned on/off when the handle is not attached.
- The icon displayed varies, depending on the signal reception from the GPS satellites.

Positioning	Display	GPS reception state status
Off	No display	GPS is set to “Off” or an error occurred.
Positioning not available		Location information could not be obtained because GPS signal could not be received. Move to a location with a clear view of the sky.
Searching for satellites		Searching for GPS satellites. Several minutes may be required to acquire satellites.
Positioning		A weak GPS signal is being received.
		A GPS signal is being received. Location information can be acquired.
		A strong GPS signal is being received. Location information can be acquired.

- GPS is set to “On” by factory default. Location and time information of video shot when positioning is enabled is recorded by the camcorder.
- If a positioning icon is not displayed after several minutes, there may be a problem with signal reception. Start shooting without location information, or move to an area with a clear view of the sky. Shooting when a positioning icon is not displayed means that location information will not be recorded.
- The GPS signal may not be received when indoors or near tall structures. Move to a location with a clear view of the sky.
- The recording of location information may be interrupted, depending on the strength of the received signal, even if a positioning icon is displayed.

## Shooting in Cine EI Mode

This mode mimics the way a film camera works, and assumes “developing” occurs in post-production.

### Cine EI mode constraints

- Functions that cannot be adjusted automatically (tracking)
  - White balance
  - Gain
  - Shutter
  - Iris
  - Auto Exposure
- Functions that cannot be configured
  - Gain
  - Noise Suppression
  - Paint menu settings
  - Scene File
  - Lens File

### Functions available in Cine EI mode only

- Exposure Index
- Monitor LUT
- RAW video recording

## Recording RAW Video

You can record RAW video to an AXS-R5 (option) by converting the signal output from the RAW OUT connector of an XDCA-FS7 (option) attached to the camcorder using an HXR-IFR5 (option) (*page 31*).

- 1 Set up the external RAW recorder unit (*page 31*).**
- 2 Set Codec > Select in the System menu to RAW.**  
Selecting RAW & XAVC-I will simultaneously record RAW video to the external RAW recorder and HD video to the XQD memory cards in the camcorder.
- 3 Set Rec Format in the System menu to RAW Output Format.**
- 4 Check that the external recorder is turned on, then press the record button on the camcorder.**

The supported RAW output formats are shown below.

#### NTSC Area

Codec >Select setting	RAW output formats
RAW / RAW &	4096 × 2160 59.94P
XAVC-I / RAW &	4096 × 2160 29.97P
XAVC-L / RAW &	4096 × 2160 23.98P
MPEG HD422	2048 × 1080 59.94P
	2048 × 1080 29.97P
	2048 × 1080 23.98P

#### PAL Area

Codec >Select setting	RAW output formats
RAW / RAW &	4096 × 2160 50P
XAVC-I / RAW &	4096 × 2160 25P
XAVC-L / RAW &	2048 × 1080 50P
MPEG HD422	2048 × 1080 25P

#### Recording status indicator

If Display On/Off (*page 74*) >HXR-IFR5 Rec Control in the VF menu is set to “On,” the RAW recording status is displayed in the viewfinder using an icon.

#### Slow & Quick Motion Recording

If S&Q Motion >Setting in the Recording menu is set to “On,” RAW video is recorded in Slow & Quick Motion mode.

RAW output Slow & Quick Motion is supported only for 2K resolution at 120/240 fps (NTSC) and 100/200 fps (PAL).

#### Note

The RAW OUT connector of the camcorder only controls recording by transmitting a Rec Control signal to the external recorder, hence the camcorder may indicate RAW video recording is in progress when the external recorder is not actually recording. Check the indicator on the external recorder to obtain the correct operating status.

## Connecting Devices using Wireless LAN

The camcorder can connect to smartphones, tablets, and other devices using wireless LAN connection by attaching the IFU-WLM3 USB Wireless LAN Module (supplied) or a CBK-WA100 Wireless Adaptor (option).

#### Note

USB wireless modules other than the IFU-WLM3 are not supported.

The following are supported from devices connected by wireless LAN.

- Remote control
  - Enables remote control of the camcorder.
- Video and audio monitoring (CBK-WA100 only)
  - Enables monitoring of the video and audio from the camcorder.
  - CBK-WA100 (option) and the Content Browser Mobile application are required.

*For details about the Content Browser Mobile application, contact your Sony sales or service representative.*

## Compatible Devices

You can use a smartphone, tablet, or computer to configure and operate the camcorder. The supported devices, OS, and browsers are shown in the following table.

Device	OS	Browser
Smartphone	Android 4.3	Chrome
	iOS7	Safari
Tablet	Android 4.3	Chrome
	iOS7	Safari
Computer	Microsoft Windows 7/	Chrome
	Microsoft Windows 8.1	
	Mac OS 10.8/10.9	Safari

## Attaching the IFU-WLM3

Plug the IFU-WML3 into the USB wireless LAN module connector (page 7).

After attaching the unit, set Wi-Fi > Wi-Fi (page 86) in the System menu to “Enable” to enable wireless LAN.

### Note

Attach/remove the IFU-WLM3 while the camcorder is turned off.

## Attaching the CBK-WA100

### Note

Attach/remove the CBK-WA100 while the camcorder is turned off.

- 1 Attach the CBK-WA100 to the mounting bracket, and tighten the two screws.

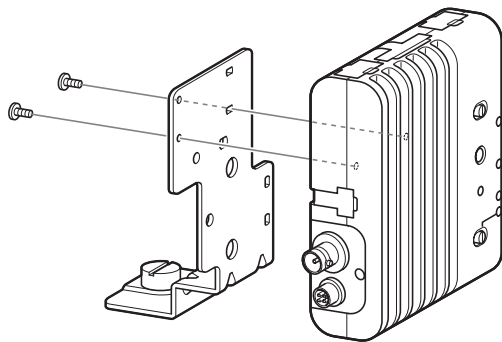

- 2 Attach the CBK-WA100 mounting bracket on the camcorder, and tighten the screws.

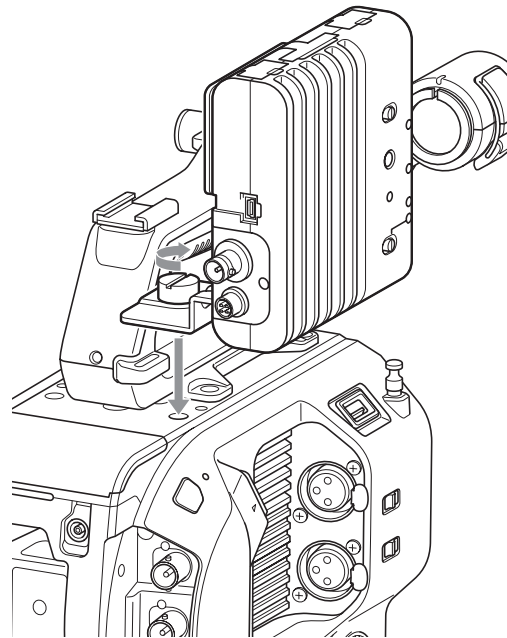

- 3 Connect the CBK-WA100 USB cable to the USB wireless LAN module connector (①), and the SDI cable to the SDI OUT connector (②).

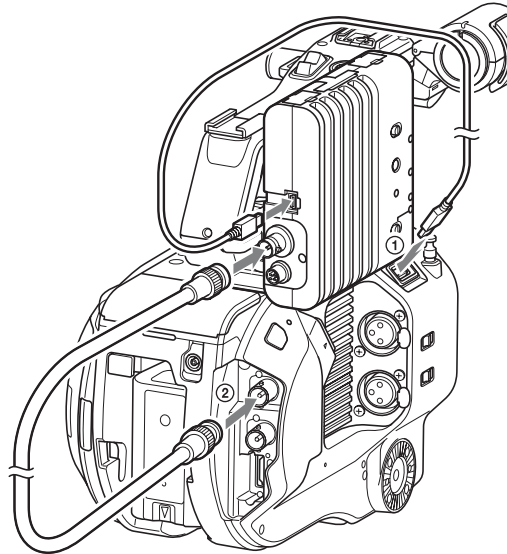

- 4 Turn the CBK-WA100 on, and then turn the camcorder on.
- 5 When connection is completed, the wireless LAN must be enabled by setting Wi-Fi > Wi-Fi (page 86) in the System menu to Enable.



#### Note

The SDI OUT output setting must be configured to use the CBK-WA100 with the camcorder (page 77).

### About the CBK-WA100

The CBK-WA100 has functions for recording proxy files (low-resolution files) on an SD card, and for transferring the files to a server via a wireless LAN. For details, refer to the operation manual for the CBK-WA100.

### One-touch Connection of NFC-enabled Devices (Using IFU-WLM3 Only)

Devices that support NFC can be connected (one-touch connection) using NFC.

- 1 **Attach an IFU-WLM3 to the camcorder (page 48), and set Wi-Fi > Wi-Fi (page 86) in the System menu to “Enable” to enable wireless LAN.**

 appears on the screen.

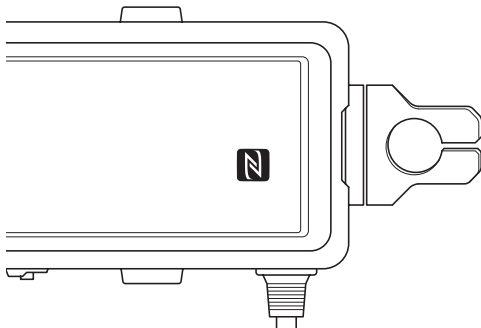

- 2 **Open “Settings” on the device, select “More,” and place a check mark in the NFC checkbox.**

The various settings will vary depending on the device. For details, refer to the instruction manual for the device.

- 3 **Touch the camcorder using the device.**

The device connects to the camcorder, launches a web browser, and displays the Wi-Fi remote control. Authentication is required the first time that the device connects.

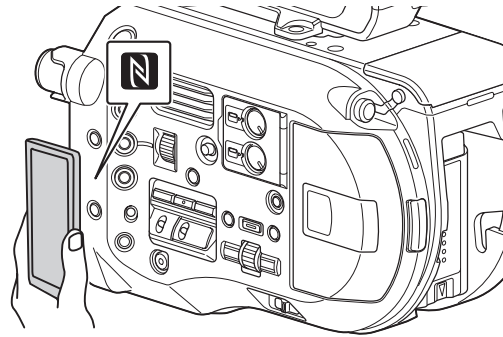

#### Notes

- Some devices with a  mark support NFC. For details, refer to the operation manual for the device.
- Disable sleep mode and screen lock beforehand.
- Touch and hold the device still until the “Content Browser Mobile” application launches (1 to 2 seconds).

## Displaying the Wi-Fi Remote Control

The Wi-Fi Remote screen is automatically resized to match the screen size of the connected device.

- 1 Connect the camcorder and device using a Wireless LAN connection (page 49).**
- 2 Launch a browser on the device and enter “http://<IP address of camcorder (Wi-Fi >IP Address in System menu)>/rm.html” in the URL bar.**

For example, if the IP address is 192.168.1.1, enter “http://192.168.1.1/rm.html” in the URL bar.

- 3 Enter the user name and password (Basic Authentication >User Name and Password in the System menu).**

When connection is successful, the Wi-Fi Remote screen appears on the device.

You use the Wi-Fi Remote screen to operate the camcorder.

You can disable the record button operation by sliding the Lock knob to the right.

### Notes

- To display the page for a smartphone, change “rm.html” to “rms.html” in the URL. To display the page for a tablet, change “rm.html” to “rmt.html” in the URL. When “rm.html” is entered, the page automatically switches for display on the corresponding device. However, the appropriate page may not be displayed, depending on the device.
- The Wi-Fi Remote screen may not match the camcorder settings under the following circumstances. If this occurs, reload the browser window.
  - If the camcorder is restarted while connected
  - If the camcorder is operated directly while connected
  - If the device has been reconnected
  - If the browser Forward/Back buttons have been used
- The Wi-Fi remote control may not function if the wireless signal strength becomes weak.

## Thumbnail Screen

# Thumbnail Screen

The thumbnail screen appears if you press the THUMBNAIL button (*page 9*). The thumbnail screen displays the clips stored on XQD memory cards as thumbnails (index pictures). You can select a clip on the thumbnail screen and start playback of that clip. The playback image can be displayed in the viewfinder and on an external monitor. Pressing the THUMBNAIL button again closes the thumbnail screen and returns to the camera image.

### Note

Only the clips recorded in the currently selected recording format are displayed on the thumbnail screen. If an expected recorded clip is not displayed, check the recording format. Take special note of this fact before formatting (initializing) media.

## Screen Layout

Information for the clip at the cursor position is displayed at the bottom of the screen.

Currently selected XQD memory card indicator  
(A lock icon is displayed if the card is protected.)

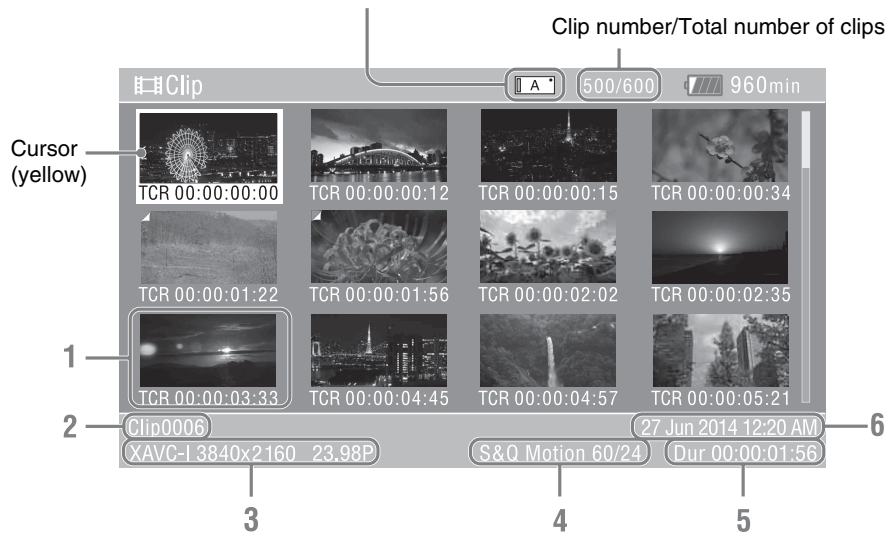

### 1. Thumbnail (index picture)

Displays the index picture of a clip. When a clip is recorded, its first frame is automatically set as the index picture.

Clip/frame information is displayed below the thumbnail. You change the information displayed using *Customize View (page 78)*  
>Thumbnail Caption in the Thumbnail menu.

### 2. Clip name

Displays the name of the selected clip.

### 3. Recording video format

Displays the file format of the selected clip.

#### 4. Special recording information

Displays the recording mode only if the clip was recorded using a special recording mode.

For Slow & Quick Motion clips, the frame rate is displayed on the right.

#### 5. Clip duration

#### 6. Creation date

## Playing Clips

### Playing Recorded Clips

You can play recorded clips when the camcorder is in recording standby (Stby) mode.

- 1 Insert an XQD memory card for playback.**
- 2 Press the THUMBNAIL button.**
- 3 Turn the SEL/SET dial (page 9) to move the cursor to the thumbnail for the clip you want to play.**
- 4 Press the SEL/SET dial.**

Playback begins from the start of the selected clip.

**You can control playback by pressing the following buttons.**

SEL/SET dial:

Pauses playback.

Press again to return to normal playback.

Press left/right buttons:

Jumps to start of clip/start of next clip.

Press and hold left/right buttons:

Fast reverse/forward.

Returns to normal playback when you release the button.

CANCEL/BACK button:

Stops playback, and returns to recording standby mode.

#### Notes

- There may be momentary picture breakup or still image display at the boundary between clips. You cannot operate the camcorder during this period.
- When you select a clip in the thumbnail screen and begin playback, there may be momentary picture breakup at the start of the clip. To view the start of the clip without breakup, put the camcorder into playback mode, pause, then use the left button of the SEL/SET dial to return to the start of the clip, and start playback again.
- You can also control playback using the supplied remote control.

## Clip Operations

On the thumbnail screen, you can operate the clips or check clip properties using the thumbnail menu.

The thumbnail menu (*page 78*) appears when you press the MENU button and select a thumbnail.

## Thumbnail Menu Operations

Turn the SEL/SET dial (*page 9*) to select a function, then press the SEL/SET dial. Press the CANCEL/BACK button (*page 9*) to return to the previous screen.

### Note

Some items cannot be selected, depending on the state when the menu was displayed.

## Thumbnail menu items

Display Clip Properties  
Set Index Picture  
Thumbnail View  
Set Shot Mark  
Set Clip Flag  
Lock/Unlock Clip  
Delete Clip  
Filter Clips  
Customize View

For details about clip operation menus, see “Thumbnail Menu” (*page 78*).

## Displaying clip properties

Select Display Clip Properties (*page 78*) in the Thumbnail menu to display the clip properties screen.

## Displaying the essence mark thumbnail screen

Select Thumbnail View (*page 78*) >Essence Mark Thumbnail in the Thumbnail menu and select the essence mark type to display a thumbnail view of the frames that have the specified essence mark.

## Displaying the filtered clip thumbnail screen

Select Filter Clips (*page 78*) in the Thumbnail menu and select a clip flag type to display only those clips that have the specified flag.

## Deleting clips

You can delete clips from XQD memory cards. Select Delete Clip >Select Clip or All Clips in the Thumbnail menu.

### Select Clip:

Deletes the selected clip. Multiple clip selection is supported.

### All Clips:

Deletes all of the displayed clips.

## Changing the information displayed on the thumbnail screen

You can change the clip/frame information displayed below the thumbnail. Select Customize View >Thumbnail Caption in the Thumbnail menu and select the information to display.

### Date Time:

Displays the date and time the clip was created and last modified.

### Time Code:

Displays the timecode.

### Duration:

Displays the duration of the clip.

### Sequential Number:

Displays a sequential number on each thumbnail.

## Menu Display and Settings

# Setup Menu Configuration and Hierarchy

Press the MENU button to display the setup menu in the viewfinder to specify various items for shooting, recording, and playback (menu can also be displayed on an external monitor). The setup menu comprises the following menus.

### User menu:

Contains menu items configured by the user using Edit User Menu.

### Edit User menu:

Contains menu items for editing the User menu.

### Camera menu:

Contains settings related to shooting.

### Paint menu:

Contains settings related to image quality.

### Audio menu:

Contains settings related to audio.

### Video menu:

Contains settings related to video output.

### VF menu:

Contains settings to the viewfinder display.

### TC/UB menu:

Contains settings related to timecode and user bits.

### Recording menu:

Contains settings related to recording.

### Thumbnail menu:

Contains settings related to thumbnail display.

### Media menu:

Contains settings related to media.

### File menu:

Contains settings related to files.

### System menu:

Contains settings related to the system.

## Setup Menu Organization

<b>User</b> (Factory settings)	Country
	Base Setting
	Rec Format
	Codec
	S&Q Motion
	Picture Cache Rec
	Simul Rec
	Output Format
	Monitor LUT
	Clip
	VF Setting
	Assignable Button
	Assignable Dial
	Format Media
Edit User Menu	
<b>Edit User</b>	Add Item
	Customize Reset
<b>Camera</b>	ISO/Gain/EI
	Auto Exposure
	Focus
	Shutter
	Color Bars
	Noise Suppression
	Flicker Reduce
	SteadyShot
	Handle Zoom
	Auto Black Balance
	AF Micro Adjustment
	Video Light Set
<b>Paint</b>	White
	Offset White
	Black
	Gamma
	Black Gamma
	Knee
	White Clip
	Detail(HD Mode)
	Skin Detail
	Aperture
	Matrix
	Multi Matrix
	Maintenance
<b>Audio</b>	Audio Input
	Audio Output

<b>Video</b>	Output On/Off
	Output Format
	Output Setting
	Monitor LUT
	Output Display
<b>VF</b>	VF Setting
	Peaking
	Zebra
	Marker
	Display On/Off
<b>TC/UB</b>	Timecode
	TC Display
	Users Bit
	HDMI TC Out
<b>Recording</b>	S&Q Motion
	Picture Cache Rec
	Simul Rec
	SDI/HDMI Rec Control
<b>Thumbnail</b>	Display Clip Properties
	Set Index Picture
	Thumbnail View
	Set Shot Mark
	Set Clip Flag
	Lock/Unlock Clip
	Delete Clip
	Filter Clips
	Customize View
<b>Media</b>	Update Media
	Format Media
	Clip
<b>File</b>	All File
	Scene File
	User Menu Item
	User Gamma
	Monitor LUT
	Monitor 3D LUT
	Lens File

<b>System</b>	Base Setting
	Codec
	Rec Format
	Genlock
	Assignable Button
	Assignable Dial
	Rec Lamp
	Fan Control
	HOLD Switch Setting
	Lens
	Language
	Clock Set
	Country
	Hours Meter
	Basic Authentication
	Wi-Fi
	GPS
	IR Remote
	Camera Battery Alarm
	Camera DC IN Alarm
	Ext. Unit Battery Alarm
	Ext. Unit DC IN Alarm
	All Reset
	APR
	Camera Config
	Version

## Setup Menu Operations

Press the MENU button to display the setup menu in the viewfinder to specify various items for shooting, recording, and playback (menu can also be displayed on an external monitor).

### Menu controls

#### MENU button (page 9)

Turns menu mode for setup menu operations on/off.

#### Left button/Right button (page 9) and SEL/SET dial (page 9)

Press the left/right button to move the cursor left/right to select menu items or settings.

Turn the SEL/SET dial to move the cursor up/down to select menu items or settings.

Press the SEL/SET dial to apply the selected item.

#### CANCEL/BACK button (page 9)

Cancels a setting before it is applied, and moves one level up in the menu hierarchy.

#### Note

The setup menu cannot be operated when in focus magnifier mode (page 37).

### Setting menu items

Turn the SEL/SET dial to move the cursor to the menu item to set, then press the SET/SEL dial to select the item.

- The menu item selection area displays up to eight lines. If the available options for an item cannot be displayed at the same time, scroll the display by moving the cursor up/down.

- If an item has a large range of available options (Example: -99 to +99), the selection area is not displayed. The current setting is highlighted to indicate that the value can be changed.
- Selecting [Execute] for a function will execute the corresponding function.
- Selecting an item that requires confirmation before execution will temporarily hide the menu and display a confirmation message. Check the message, and then select whether to execute or cancel the function.

### Entering a character string

When you select an item, such as a file name, which requires character entry, the character entry screen appears.

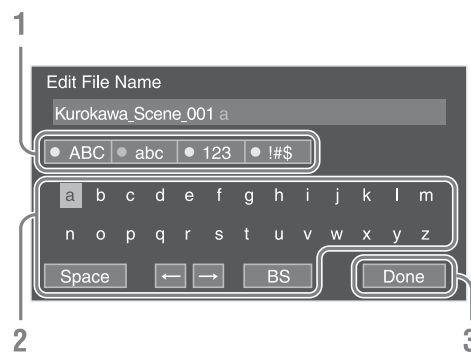

#### 1 Turn the SEL/SET dial to select a character type, then press the dial.

ABC: Uppercase alphabetic characters  
abc: Lowercase alphabetic characters  
123: Numeric characters  
!#\$: Special characters

#### 2 Select a character from the selected character type, then press the dial.

The cursor moves to the next field.

Space: Enters a space character at the cursor position.

←/→ : Moves the position of the cursor.

BS: Deletes the character on the left of the cursor (backspace).

#### 3 When finished, select [Done] and press the dial.

The character string is confirmed and the character entry screen disappears.



# Setup Menu List

This section describes the function and settings of the items in each menu.  
Factory default settings are shown in bold (for example, **18dB** ).

## User Menu

User		
Item	Sub-item setting	Description
<b>Country</b> Region settings	See Country in the System menu.	
<b>Base Setting</b> Base settings	See Base Setting in the System menu.	
<b>Rec Format</b> Recording format settings	See Rec Format in the System menu.	
<b>Codec</b> Codec settings	See Codec in the System menu.	
<b>S&amp;Q Motion</b> Slow & Quick Motion mode settings	See S&Q Motion in the Recording menu.	
<b>Picture Cache Rec</b> Picture cache recording mode settings	See Picture Cache Rec in the Recording menu.	
<b>Simul Rec</b> Simultaneous recording settings	See Simul Rec in the Recording menu.	
<b>Output Format</b> Output format settings	See Output Format in the Video menu.	
<b>Monitor LUT</b> Monitor LUT settings	See Monitor LUT in the Video menu.	
<b>Clip</b> Settings related to clip names	See Clip in the Media menu.	
<b>VF Setting</b> Viewfinder settings	See VF Setting in the VF menu.	
<b>Assignable Button</b> Settings for assigning functions to assignable buttons	See Assignable Button in the System menu.	
<b>Assignable Dial</b> Settings for assigning functions to assignable dials	See Assignable Dial in the System menu.	
<b>Format Media</b> Format (initializes) memory cards	See Format Media in the Media menu.	
<b>Edit User Menu</b> Edit the User menu items		Edits the items in the User menu. When “Edit User Menu” is selected, the Edit User menu moves to the top level, and the menu items are displayed.

## Edit User Menu

The Edit User menu is displayed at the top level when “Edit User Menu” is selected in the User menu.

Edit User		
Item	Sub-item setting	Description
<b>Add Item</b> Add an item to the User menu		Adds a menu item to the User menu.
<b>Customize Reset</b> Reset the items in the User menu		Restores the menu items registered in the User menu to the factory default.
Menu item selected during editing	Delete	Deletes the registered menu item from the User menu.
	Move	Rearranges the registered menu items within the User menu.
	Edit Sub Item	Deletes the registered menu sub-item in the User menu.

## Camera Menu

Camera		
Item	Sub-item setting	Description
<b>ISO/Gain/EI</b> Gain settings	Mode	Selects the gain setting mode.
	ISO/dB	
	ISO/Gain<H>	Sets the <H> gain preset value.
	When Mode is set to ISO and dynamic range is 460%. ISO 800 / ISO 1000 / ISO 1250 / ISO 1600 / ISO 2000 / ISO 2500 / <b>ISO 3200</b> / ISO 4000 / ISO 5000 / ISO 6400	When Mode is set to ISO and dynamic range is 1300% (Gamma Category is set to S-Log3). ISO 2000 / ISO 2500 / ISO 3200 / ISO 4000 / ISO 5000 / ISO 6400 / <b>ISO 8000</b> / ISO 10000 / ISO 12500 / ISO 16000
	When Mode is set to ISO and dynamic range is 800%. ISO 1600 / ISO 2000 / ISO 2500 / ISO 3200 / ISO 4000 / ISO 5000 / <b>ISO 6400</b> / ISO 8000 / ISO 10000 / ISO 12500	When Mode is set to dB. -3dB / 0dB / 3dB / 6dB / 9dB / <b>12dB</b> / 18dB
	ISO/Gain<M> (Same settings as ISO/ Gain<H>)	Sets the <M> gain preset value.
	ISO/Gain<L> (Same settings as ISO/ Gain<H>)	Sets the <L> gain preset value.

Camera		
Item	Sub-item setting	Description
	Exposure Index<H> 500EI / 4.0E 640EI / 4.3E 800EI / 4.7E 1000EI / 5.0E 1250EI / 5.3E 1600EI / 5.7E 2000EI / 6.0E 2500EI / 6.3E <b>3200EI / 6.7E</b> 4000EI / 7.0E 5000EI / 7.3E 6400EI / 7.7E 8000EI / 8.0E	Sets the <H> exposure index value. Available in Cine EI mode only.
	Exposure Index<M> (Same settings as Exposure Index<H>)	Sets the <M> exposure index value.
	Exposure Index<L> (Same settings as Exposure Index<H>)	Sets the <L> exposure index value.
	Shockless Gain On/ <b>Off</b>	Turns the shockless gain function on/off.
<b>Auto Exposure</b> Automatic exposure adjustment settings	Level -2.0 / -1.75 / -1.5 / -1.25 / -1.0 / -0.75 / -0.5 / -0.25 / <b>0</b> / +0.25 / +0.5 / +0.75 / +1.0 / +1.25 / +1.5 / +1.75 / +2.0	Sets the brightness level for the automatically detected exposure.
	Mode Backlight / <b>Standard</b> / Spotlight	Sets the control mode. Backlight: Backlight mode (mode for reduced darkening of a subject when the subject is backlit) Standard: Standard mode Spotlight: Spotlight mode (mode for reduced clipped whites when subject is lit by spotlighting)
	Speed -99 to +99 ( <b>±0</b> )	Sets the adjustment speed.
	AGC On / <b>Off</b>	Turns the AGC (auto gain control) function on/off.

Camera		
Item	Sub-item setting	Description
	AGC Limit When ISO/Gain/EI > Mode is set to dB. 3dB / 6dB / 9dB / 12dB / <b>15dB</b> / 18dB When ISO/Gain/EI > Mode is set to ISO and dynamic range is 460%. ISO1000 / ISO1600 / ISO2000 / ISO3200 / <b>ISO4000</b> / ISO6400 When ISO/Gain/EI > Mode is set to ISO and dynamic range is 800%. ISO2000 / ISO3200 / ISO4000 / ISO6400 / <b>ISO8000</b> / ISO12500 When ISO/Gain/EI > Mode is set to ISO and dynamic range is 1300%. ISO2500 / ISO4000 / ISO5000 / ISO8000 / <b>ISO10000</b> / ISO16000	Sets the maximum gain of the AGC function.
	Auto Shutter On / <b>Off</b>	Turns the auto shutter control function on/off.
	A.SHT Limit 1/100 / 1/150 / 1/200 / 1/250 / <b>1/2000</b>	Sets the fastest shutter speed of the auto shutter function.
	Clip High light On / <b>Off</b>	Turns the function that ignores brightest areas to provide a flatter reaction to high luminance on/off.
	Detect Window <b>1</b> / 2 / 3 / 4 / 5 / 6	Sets the light meter range for automatically adjusting the exposure according to the brightness of the subject. (Not available when adjusting exposure manually)
	Detect Window Indication On / <b>Off</b>	Turns the Detect Window function on/off.
<b>Focus</b>	AF Assist On / <b>Off</b>	When set to On, allows you to temporarily override auto focus and set focus manually.
Focus settings		

Camera		
Item	Sub-item setting	Description
<b>Shutter</b> Electronic shutter operating condition settings	Mode	Selects the operating mode of the electronic shutter.
	<b>Speed</b> / Angle / ECS / Off	Speed/Angle (standard mode): Used for shooting fast-moving subjects clearly. Selects the mode for setting the shutter speed in seconds (Speed) or as a shutter angle (Angle). ECS (Extended Clear Scan): Used for shooting without scrolling horizontal bars appearing in the viewfinder.
	Shutter Speed 1/3 to 1/9000	Sets the shutter speed when Mode is set to Speed. The available settings vary depending on the frame frequency of the selected video format.
	Shutter Angle 5.625° / 11.25° / 22.5° / 45° / 90° / 120° / 144° / 150° / 172.8° / <b>180°</b> / 216° / 300°	Sets the shutter angle when Mode is set to Angle.
ECS Frequency 23.99 to 8000 ( <b>60</b> )	Sets the ECS frequency when Mode is set to ECS. The available settings vary depending on the frame frequency of the selected video format.	
<b>Color Bars</b> Color bar settings	Setting On / <b>Off</b>	Turns the color bars on/off.
	Type <b>ARIB</b> / SMPTE / 75% / 100%	Selects the color bar type.
<b>Noise Suppression</b> Noise suppression settings	Setting On / Off	Turns the noise suppression function on/off. (Enabled when Base Setting >Shooting Mode in the System menu is set to Custom)
	Level Low / <b>Mid</b> / High	Sets the noise suppression level.
<b>Flicker Reduce</b> Flicker correction settings	Mode Auto / On / <b>Off</b>	Sets the flicker correction mode.
	Frequency 50Hz / <b>60Hz</b>	Sets the frequency of the power source supplying the lighting that is causing the flicker.
<b>SteadyShot</b> Image stabilization settings	Setting Active SteadyShot / <b>SteadyShot</b> / Off	Turns the image stabilization function on/off. <b>Note</b> Enabled when a compatible lens is attached.
<b>Handle Zoom</b> Handle zoom settings	Zoom Speed Type Fix / <b>Variable</b> / Off	Sets the mode of the zoom lever on the handle. <b>Note</b> Disabled when the handle is not attached.
	Zoom Speed 1 to 8 ( <b>3</b> )	Sets the speed of the handle zoom. (Enabled when Zoom Speed Type is set to Fix) <b>Note</b> Disabled when the handle is not attached.
	Auto Black Balance Execute / Cancel	Runs the auto black balance function. <b>Notes</b> • The auto black balance function cannot be run if the iris is not closed. Attach the lens cap and then execute. • Cannot be run during recording or color bar display. • Cannot be run when in Interval Rec mode, Frame Rec mode, Slow & Quick Motion mode, or Slow Shutter mode.

Camera		
Item	Sub-item setting	Description
<b>AF Micro Adjustment</b> Focus position micro adjustment (Enabled when LA-EA2/4 (option) is used)	Setting On / <b>Off</b>	Turns the auto focus micro adjustment function on/off.
	Amount –20 to <b>0</b> to +20	Sets the auto focus micro adjustment level. Use the following procedure to adjust A-mount lenses. <b>1</b> Attach the lens you want to adjust using an LA-EA2/4 (option). <b>2</b> Set Setting to On, and adjust the Amount value. Positive values move the focus behind the subject, and negative values move the focus in front of the subject. It is recommended that you check the result using one-push AF, for example, while adjusting the focus.
	Clear All Execute / Cancel	Initializes the saved adjustment values.
<b>Video Light Set</b> Video light settings (when using HVL-LBPC (option))	Video Light Set <b>Power Link</b> / Rec Link / Rec Link + Stby	Sets the lighting control method for the video light attached to the multi-interface shoe. Power Link: Turns the video light on/off when the camcorder is turned on/off. Rec Link: Turns the video light on/off when the camcorder starts/stops recording. Rec Link + Stby: Turns the video light on/off when the camcorder is recording or in standby mode.

## Paint Menu

Paint		
Item	Sub-item setting	Description
<b>White</b> White balance settings	Color Temp<A> 1500K to 50000K ( <b>3200K</b> )	Displays the white balance color temperature saved in memory A.
	Color Temp. Balance<A> -99 to +99 ( <b>±0</b> )	Sets the white balance gain value saved in memory A (linked to R gain and B gain).
	R Gain<A> -99 to +99 ( <b>±0</b> )	Sets the white balance R gain value saved in memory A.
	B Gain<A> -99 to +99 ( <b>±0</b> )	Sets the white balance B gain value saved in memory A.
	Color Temp<B> 1500K to 50000K ( <b>3200K</b> )	Displays the white balance color temperature saved in memory B.
	Color Temp. Balance<B> -99 to +99 ( <b>±0</b> )	Sets the white balance gain values saved in memory B (linked R gain and B gain).
	R Gain<B> -99 to +99 ( <b>±0</b> )	Sets the white balance R gain value saved in memory B.
	B Gain<B> -99 to +99 ( <b>±0</b> )	Sets the white balance B gain value saved in memory B.
	Filter White Memory On / <b>Off</b>	Turns the function that sets the white balance memory area for each ND filter on/off. On: Sets the white balance memory for each ND filter. Off: Sets white balance memory common to all ND filters.
	Shockless White Off / <b>1</b> / 2 / 3	Sets the white balance response speed when switching white balance mode. Off: Switches instantaneously. 1 to 3: Switches more slowly the higher the number.
	White Switch <B> <b>Memory</b> / ATW	Selects the white balance adjustment mode that is selected when the WHT BAL switch is set to B.
	ATW Speed 1 / 2 / <b>3</b> / 4 / 5	Sets the response speed in ATW mode. 1: Fastest response speed
	Color Temp<P> 1500K to 50000K ( <b>3200K</b> )	Sets the white balance preset value.
	C.Temp BAL <P> -99 to +99 ( <b>±0</b> )	Sets more precise color temperature settings, for use when satisfactory video cannot be obtained with Color Temp <P>.
	R Gain <P> -99 to +99 ( <b>±0</b> )	Specifies the R gain preset value.
	B Gain <P> -99 to +99 ( <b>±0</b> )	Specifies the B gain preset value.
AWB Enable<P> On / <b>Off</b>	Turns execution of auto white balance on/off when the WHT BAL switch is set to PRESET.	

<b>Paint</b>		
<b>Item</b>	<b>Sub-item setting</b>	<b>Description</b>
<b>Offset White</b> White balance offset settings	Offset White<A> On / <b>Off</b>	Selects whether to add (On) or not to add (Off) an offset value to the white balance in memory A.
	Warm Cool <A> –99 to +99 ( <b>±0</b> )	Sets the offset added to the white balance in memory A as a color temperature when Offset White<A> is set to “On.”
	Warm Cool Balance<A> –99 to +99 ( <b>±0</b> )	Sets a more precise color temperature, for use when a satisfactory image cannot be obtained using Warm Cool <A>.
	Offset White<B> On / <b>Off</b>	Selects whether to add (On) or not to add (Off) an offset value to the white balance in memory B.
	Warm Cool <B> –99 to +99 ( <b>±0</b> )	Sets the offset added to the white balance in memory B as a color temperature when Offset White<B> is set to “On.”
	Warm Cool Balance<B> –99 to +99 ( <b>±0</b> )	Sets a more precise color temperature, for use when a satisfactory image cannot be obtained using Warm Cool <B>.
	Offset White<ATW> On / <b>Off</b>	Selects whether to add (On) or not to add (Off) an offset value to the ATW white balance.
	Warm Cool <ATW> –99 to +99 ( <b>±0</b> )	Sets the offset added to the ATW white balance as a color temperature when Offset White<ATW> is set to “On.”
	Warm Cool Balance<ATW> –99 to +99 ( <b>±0</b> )	Sets a more precise color temperature, for use when a satisfactory image cannot be obtained using Warm Cool <ATW>.
	<b>Black</b> Black settings	Setting <b>On / Off</b>
Master Black –99 to +99 ( <b>±0</b> )		Sets the master black level.  <b>Note</b> Fine adjustment is supported by turning the SEL/SET dial slowly. In this case, the displayed value may not change.
R Black –99 to +99 ( <b>±0</b> )		Sets the R black level.
B Black –99 to +99 ( <b>±0</b> )		Sets the B black level.



Paint		
Item	Sub-item setting	Description
<b>Gamma</b> Gamma correction settings	Setting <b>On / Off</b>	Turns the gamma correction function on/off.
	Step Gamma 0.35 to <b>0.45</b> to 0.90	Sets a gamma correction value in 0.05 steps.
	Master Gamma -99 to +99 ( <b>±0</b> )	Sets the master gamma level.
	R Gamma -99 to +99 ( <b>±0</b> )	Sets the R gamma level.
	G Gamma -99 to +99 ( <b>±0</b> )	Sets the G gamma level.
	Gamma Category <b>STD</b> / HG / User / S-Log3	Selects use of standard gamma (STD), HyperGamma (HG), user gamma (User), or S-Log3.
	Gamma Select When Gamma Category is set to STD. STD1 DVW / STD2 x 4.5 / STD3 x 3.5 / STD4 240M / <b>STD5 R709</b> / STD6 x 5.0 When Gamma Category is set to HG. HG1 3250G36 / HG2 4600G30 / HG3 3259G40 / HG4 4609G33 / HG7 8009G40 / HG8 8009G33 When Gamma Category is set to User. User 1 / User 2 / User 3 / User 4 / User 5 When Gamma Category is set to S-Log3. S-Log3	Selects the gamma table used for gamma correction.
	<b>Black Gamma</b> Setting On / <b>Off</b>	Turns the black gamma correction function on/off.
Range Low / Mid / <b>High</b>	Selects the effective range of the black gamma correction.	
Master Black Gamma -99 to +99 ( <b>±0</b> )	Sets the master black gamma level.	

**Note**

The Black Gamma and Knee >Knee Saturation functions cannot be used at the same time.

<b>Paint</b>		
<b>Item</b>	<b>Sub-item setting</b>	<b>Description</b>
<b>Knee</b>	Setting <b>On / Off</b>	Turns the knee correction function on/off. (Enabled when Gamma >Gamma Category is set to STD)
	Auto Knee <b>On / Off</b>	Turns the auto knee correction function on/off.
	Point 75% to 109% ( <b>90%</b> )	Sets the knee point.
	Slope -99 to +99 ( <b>±0</b> )	Sets the knee slope.
	Knee Saturation <b>On / Off</b>	Enables/disables knee saturation adjustment (adjusts coloring above the knee point).
	Knee Saturation Level -99 to +99 ( <b>±0</b> )	Sets the level for adjusting the coloring above the knee point (knee saturation).
<b>White Clip</b> White clip adjustment settings	Setting <b>On / Off</b>	Turns the white clip adjustment function on/off.
	Level When Country is not set to PAL Area. 90.0% to 109.0% ( <b>108.0%</b> )	Sets the white clip level.
	When Country is set to PAL Area. 90.0% to 109.0% ( <b>105.0%</b> )	

<b>Paint</b>		
<b>Item</b>	<b>Sub-item setting</b>	<b>Description</b>
<b>Detail</b> Detail adjustment settings	Setting On / <b>Off</b>	Turns the detail adjustment function on/off.
	Level –99 to +99 ( <b>±0</b> )	Sets the detail level.
	H/V Ratio –99 to +99 ( <b>±0</b> )	Sets the mix ratio between the H detail level and the V detail level.
	Crispening –99 to +99 ( <b>±0</b> )	Sets the crispening level.
	Level Depend On / Off	Turns the level dependence adjustment function on/off.
	Level Depend Level –99 to +99 ( <b>±0</b> )	Sets the level dependence level.
	Frequency –99 to +99 ( <b>±0</b> )	Sets the center frequency of the detail (detail thickness). The detail is thinner the higher the center frequency, and thicker the lower the center frequency.
	Knee Aperture On / <b>Off</b>	Turns the knee aperture correction function on/off.
	Knee Aperture Level –99 to +99 ( <b>±0</b> )	Sets the knee aperture level.
	Limit –99 to +99 ( <b>±0</b> )	Sets the detail limiter for both the white-side and black-side directions.
	White Limit –99 to +99 ( <b>±0</b> )	Sets the white-side detail limiter.
	Black Limit –99 to +99 ( <b>±0</b> )	Sets the black-side detail limiter.
	V Black Limit –99 to +99 ( <b>±0</b> )	Sets the black-side V detail limiter.
	V Detail Creation NAM / <b>Y</b> / G / G+R	Sets the signal source for creating the V detail to NAM (G or R, whichever is higher), Y, G, or G+R.
	<b>Skin Detail</b> Skin detail correction settings	Setting On / <b>Off</b>
Area Detection Execute / Cancel		Detects the color used for skin detail correction. Execute: Run detection
Area Indication On / <b>Off</b>		Turns the function that displays zebra in areas of the color used for skin detail correction on/off.
Level –99 to +99 ( <b>±0</b> )		Sets the skin detail level.
Saturation –99 to +99 ( <b>±0</b> )		Sets the saturation of the color targeted for skin detail correction.
Hue <b>0</b> to 359		Sets the hue of the color targeted for skin detail correction.
Width 0 to 90 ( <b>40</b> )		Sets the range for the hue of the color targeted for skin detail correction.
<b>Aperture</b> Aperture correction settings	Setting On / Off	Enables/disables aperture correction (processing that improves resolution by adding a high-frequency aperture signal to the video signal to correct deterioration due to high-frequency characteristics).
	Level –99 to +99 ( <b>±0</b> )	Sets the aperture correction level.

<b>Paint</b>			
<b>Item</b>	<b>Sub-item setting</b>	<b>Description</b>	
<b>Matrix</b> Matrix correction settings	Setting <b>On / Off</b>	Turns the matrix correction function on/off.	
	Adaptive Matrix <b>On / Off</b>	Turns the adaptive matrix function on/off.	
	Preset Matrix <b>On / Off</b>	Turns the preset matrix function on/off.	
	Preset Select <b>Standard</b> High Saturation FL Light Cinema F55 709 Like	Selects a preset matrix.	
	User Matrix <b>On / Off</b>	Turns the user matrix correction function on/off.	
	Level -99 to +99 ( <b>±0</b> )	Adjusts the color saturation of the entire image.	
	Phase -99 to +99 ( <b>±0</b> )	Adjusts the color tone (phase) of the entire image.	
	User Matrix R-G -99 to +99 ( <b>±0</b> )	Sets a user-defined R-G user matrix.	
	User Matrix R-B -99 to +99 ( <b>±0</b> )	Sets a user-defined R-B user matrix.	
	User Matrix G-R -99 to +99 ( <b>±0</b> )	Sets a user-defined G-R user matrix.	
	User Matrix G-B -99 to +99 ( <b>±0</b> )	Sets a user-defined G-B user matrix.	
	User Matrix B-R -99 to +99 ( <b>±0</b> )	Sets a user-defined B-R user matrix.	
	User Matrix B-G -99 to +99 ( <b>±0</b> )	Sets a user-defined B-G user matrix.	
	<b>Multi Matrix</b> Multi matrix correction settings	Setting <b>On / Off</b>	Turns the multi matrix correction function on/off.
		Area Indication <b>On / Off</b>	Turns the area indication function on/off.
Color Detection Execute / Cancel		Detects the color used for multi matrix correction.	
Axis <b>B / B+ / MG- / MG / MG+ / R / R+ / YL- / YL / YL+ / G- / G / G+ / CY / CY+ / B-</b>		Selects the axis.	
Hue -99 to +99 ( <b>±0</b> )		Sets the hue of the color used for multi matrix correction.	
Saturation -99 to +99 ( <b>±0</b> )		Sets the saturation of the color used for multi matrix correction.	
<b>Maintenance</b> Maintenance settings	Test Saw <b>On / Off</b>	Turns the test signal on/off.	

## Audio Menu

Audio		
Item	Sub-item setting	Description
<b>Audio Input</b> Audio input settings	CH1 Input Select INPUT1 / <b>Internal MIC</b> / Shoe 1	Switches the input source for recording on channel 1.
	CH2 Input Select INPUT1 / INPUT2 / <b>Internal MIC</b> / Shoe 2	Switches the input source for recording on channel 2.
	INPUT1 Reference -60dB / <b>-50dB</b> / -40dB	Sets the reference recording level for XLR microphone input from INPUT1.
	INPUT2 Reference -60dB / <b>-50dB</b> / -40dB	Sets the reference recording level for XLR microphone input from INPUT2.
	Audio Input Level 0 to <b>+99</b>	Sets the audio input level.
	CH1 Wind Filter On / <b>Off</b>	Enables/disables the wind reduction filter for channel 1 recording.
	CH2 Wind Filter On / <b>Off</b>	Enables/disables the wind reduction filter for channel 2 recording.
	Limiter Mode <b>Off</b> / -6dB / -9dB / -12dB / -15dB / -17dB	Selects the limiter characteristic for large input signals when adjusting the audio input level manually.
	AGC Mode <b>Mono</b> / Stereo	Sets the auto level adjustment mode.
	AGC Spec <b>-6dB</b> / -9dB / -12dB / -15dB / -17dB	Selects the AGC characteristic.
	1kHz Tone on Color Bars On / <b>Off</b>	Turns the 1 kHz reference tone signal on/off when displaying color bars.
	CH1 Level Audio Input Level / Side / <b>Lvl+Side</b>	Sets the combination of audio input level adjustments enabled for recording channel 1.
	CH2 Level Audio Input Level / Side / <b>Lvl+Side</b>	Sets the combination of audio input level adjustments enabled for recording channel 2.
	<b>Audio Output</b> Audio output settings	Monitor CH <b>MIX</b> / CH1 / CH2
Monitor Volume 0 to 15 ( <b>7</b> )		Adjusts the monitor audio level output to the headphone connector and built-in speaker.
Headphone Out <b>Mono</b> / Stereo		Selects whether the headphone connector output is monaural (Mono) or stereo (Stereo).
Alarm Volume 0 to 7 ( <b>4</b> )		Adjusts the volume of the alarm.
Output Limiter On / <b>Off</b>		Turns the audio output limiter on/off.

## Video Menu

Video		
Item	Sub-item setting	Description
<b>Output On/Off</b> Video output settings	SDI <b>On / Off</b>	Turns SDI output on/off.
	HDMI <b>On / Off</b>	Turns HDMI output on/off.
<b>Output Format</b> Output format settings	SDI	Sets the SDI and HDMI output resolution.
	HDMI	For details about settings, see “ <i>Video Formats and Output Signals</i> ” (page 94).
<b>Output Setting</b> Output conversion mode settings	HDMI Target Device <b>Recorder / Monitor</b>	Sets the type of HDMI input device connected to the HDMI output. Recorder: Applies the SDI1 MLUT settings when in Cine EI mode. Monitor: Applies the SDI2 MLUT and Output Display settings when in Cine EI mode.
	4K/2K to HD Conv. Edge Crop / <b>Letter Box</b>	Sets the 17:9 to 16:9 video output conversion mode.

Video		
Item	Sub-item setting	Description
<b>Monitor LUT</b> Monitor LUT settings Available in Cine EI mode only.	Category	Sets the type of Look applied as a monitor LUT.
	<b>LUT</b> / Look Profile / User 3D LUT	LUT: Outputs video with applied preset LUT or user LUT. Look Profile: Outputs video close to print film or video which is suitable as the start point of color grading, by selecting a Look number. User 3D LUT: Outputs video with applied user 3D LUT.
	LUT Select	Selects the LUT type, when Monitor LUT >Category is set to LUT.
	<b>P1: 709(800%)</b>	709(800%): Signal with ITU-R709 base curve with extended dynamic range up to 800%.
	P2: HG8009G40	HG8009G40: Signal using HyperGamma with 800% dynamic range, 109% white limit, and 18% gray card video output of 40%.
	P3: HG8009G33	HG8009G33: Signal using HyperGamma with 800% dynamic range, 109% white limit, and 18% gray card video output of 33%.
	P5: S-Log3	S-Log3: Log signal with 1300% dynamic range that mimics film characteristics, close to Cineon Log curve. (Enabled when Base Setting >Color Space in the System menu is set to SGamut3.Cine/SLog3)
	U1	U1 to U6: User LUT signals imported from an SD card.
	U2	
	U3	
U4		
U5		
U6		
	Look Profile Select	Selects the type of Look profile, when Monitor LUT >Category is set to Look Profile.
	<b>1: LC-709</b>	
	2: LC-709typeA	
	3: SLog2-709	
	4: Cine+709	
	User 3D LUT Select	Selects the type of user 3D LUT.
	<b>User 3D-1</b>	
	User 3D-2	
	User 3D-3	
	User 3D-4	
	SDI1 & Internal Rec	Selects whether to apply monitor LUT to the SDI OUT1 output video and the video recorded on XQD memory cards.
	MLUT On / <b>MLUT Off</b>	
	SDI2	Selects whether to apply monitor LUT to the SDI OUT2 output video.
	MLUT On / <b>MLUT Off</b>	
	HDMI	Displays whether monitor LUT is applied to the HDMI output video.
	MLUT On / <b>MLUT Off</b>	
	Viewfinder	Selects whether to apply monitor LUT to the viewfinder output video.
	MLUT On / <b>MLUT Off</b>	
<b>Output Display</b>	SDI2	Selects whether to superimpose menus and status on the SDI output signal and HDMI output signal.
Output signal settings	<b>On / Off</b>	
	HDMI	
	<b>On / Off</b>	

## VF Menu

VF		
Item	Sub-item setting	Description
<b>VF Setting</b> Viewfinder settings	Brightness –99 to +99 ( <b>±0</b> )	Adjusts the brightness of the viewfinder image.
	Color Mode <b>Color</b> / B&W	Selects the display mode of the viewfinder in E-E/recording mode.
<b>Peaking</b> Peaking settings	Setting On / <b>Off</b>	Turns the peaking function on/off.
	Peaking Type <b>Normal</b> / Color	Selects the peaking type. Normal: Normal peaking Color: Color peaking
	Frequency <b>Normal</b> / High	Selects the peaking frequency.
	Normal Peaking Level 0 to 99 ( <b>50</b> )	Sets the normal peaking level.
	Color <b>B&amp;W</b> / Red / Yellow / Blue	Selects the color of the color peaking signal.
	Color Peaking Level 0 to 99 ( <b>50</b> )	Sets the color peaking level.
	<b>Zebra</b> Zebra pattern settings	Setting On / <b>Off</b>
	Zebra Select <b>1</b> / 2 / Both	Selects the zebra pattern type (Zebra 1, Zebra 2, Both).
	Zebra1 Level 50% to 107% ( <b>70%</b> )	Sets the Zebra 1 display level.
	Zebra1 Aperture Level 1% to 20% ( <b>10%</b> )	Sets the Zebra 1 aperture level.
	Zebra2 Level 52% to 109% ( <b>100%</b> )	Sets the Zebra 2 display level.



VF		
Item	Sub-item setting	Description
Marker Marker display settings	Setting <b>On / Off</b>	Turns the display of all markers on/off.
	Color <b>White</b> / Yellow / Cyan / Green / Magenta / Red / Blue	Selects the marker signal color.
	Center Marker 1 / 2 / 3 / 4 / <b>Off</b>	Turns the center marker on/off.
	Safety Zone <b>On / Off</b>	Turns the safety zone marker on/off.
	Safety Area 80% / <b>90%</b> / 92.5% / 95%	Selects the size of the safety zone marker (as a percentage of total screen size).
	Aspect Marker Line / Mask / <b>Off</b>	Selects the type of aspect marker.
	Aspect Mask 0 to 15 ( <b>12</b> )	Sets the level of the video signal outside the marker relative to the signal inside the marker as a percentage.
	Aspect Safety Zone <b>On / Off</b>	Turns the aspect safety zone marker on/off.
	Aspect Safety Area 80% / <b>90%</b> / 92.5% / 95%	Selects the size of the aspect safety zone marker (as a percentage of total screen size).
	Aspect Select <b>4:3</b> / 1.66:1 / 1.85:1 / 2.35:1 / 2.4:1	Sets the mode when displaying the aspect marker.
	User Box <b>On / Off</b>	Turns the box cursor display on/off.
	User Box Width 3 to 479 ( <b>240</b> )	Sets the box cursor width (distance from the center to the left and right edges).
	User Box Height 3 to 269 ( <b>135</b> )	Sets the box cursor height (distance from the center to the top and bottom edges).
	User Box H Position -476 to +476 ( <b>0</b> )	Sets the horizontal position of the box cursor center.
	User Box V Position -266 to +266 ( <b>0</b> )	Sets the vertical position of the box cursor center.
	100% Marker <b>On / Off</b>	Turns the 100% marker on/off.
Guide Frame <b>On / Off</b>	Turns the guide frame display on/off.	

VF		
Item	Sub-item setting	Description
Display On/Off Display item settings	Setting <b>On / Off</b>	Selects the items to display in the viewfinder.
	Shutter Setting <b>On / Off</b>	
	ND Filter Position <b>On / Off</b>	
	Gain Setting <b>On / Off</b>	
	Rec/Play Status <b>On / Off</b>	
	HXR-IFR5 Rec Control <b>On / Off</b>	
	Color Temp. <b>On / Off</b>	
	Frame Rate <b>On / Off</b>	
	Battery Remain <b>On / Off</b>	
	Timecode <b>On / Off</b>	
	Audio Manual <b>On / Off</b>	
	Audio Level Meter <b>On / Off</b>	
	Media Status <b>On / Off</b>	
	Focus Position <b>Meter / Feet / Off</b>	
	Iris Position <b>On / Off</b>	
	Zoom Position <b>Number / Bar / Off</b>	
	SteadyShot <b>On / Off</b>	
	Focus Mode <b>On / Off</b>	
	Focus Area Indicator <b>On / Off</b>	
	Focus Indicator <b>On / Off</b>	
	Auto Shutter <b>On / Off</b>	
	AGC <b>On / Off</b>	
	Auto Iris <b>On / Off</b>	
	AE Mode <b>On / Off</b>	

VF		
Item	Sub-item setting	Description
	Auto Exposure Level	<b>On</b> / Off
	White Balance Mode	<b>On</b> / Off
	SDI/HDMI Rec Control	<b>On</b> / Off
	Rec Format	<b>On</b> / Off
	Gamma	<b>On</b> / Off
	Timecode Lock	<b>On</b> / Off
	Wi-Fi Condition	<b>On</b> / Off
	Video Signal Monitor	<b>Off</b> / Waveform / Vector / Histogram
	Clip Name	On / <b>Off</b>
	Focus Assist Indicator	<b>On</b> / Off
	Focus Area Marker	<b>On</b> / Off
	Video Level Warning	<b>On</b> / Off
	Clip Number	<b>On</b> / Off
	GPS	<b>On</b> / Off
	Level Gauge	<b>On</b> / Off
	Lens Info	Meter / Feet / <b>Off</b>
	Notice Message	<b>On</b> / Off

## TC/UB Menu

TC/UB		
Item	Sub-item setting	Description
<b>Timecode</b> Timecode settings	Mode <b>Preset</b> / Regen / Clock	Sets the timecode running mode. Preset: Starts running from a preset value. Regen: Starts running from the timecode of the end of the previous clip. Clock: Uses the internal clock as the timecode.
	Run <b>Rec Run</b> / Free Run	Rec Run: Runs only when recording. Free Run: Always running, regardless of camcorder operation.
	Setting	Sets the timecode to an arbitrary value. SET: Set the value.
	Reset Execute / Cancel	Resets the timecode to 00:00:00:00. Execute: Reset timecode
	TC Format <b>DF</b> / NDF	Sets the timecode format. DF: Drop Frame NDF: Non-Drop Frame
	<b>TC Display</b> Time data display settings	Display Select <b>Timecode</b> / Users Bit / Duration
<b>Users Bit</b> Settings related to user bits.	Mode <b>Fix</b> / Time	Sets the user bit mode. Fix: Uses an arbitrary fixed value in user bits. Time: Uses the current date and time in user bits.
	Setting	Sets the user bits to an arbitrary value.
<b>HDMI TC Out</b>	Setting On / <b>Off</b>	Sets whether to output the timecode to devices for other purposes, using HDMI.

## Recording Menu

Recording		
Item	Sub-item setting	Description
<b>S&amp;Q Motion</b> Slow & Quick Motion mode settings	Setting On / <b>Off</b>	Turns Slow & Quick Motion on/off.
	High Frame Rate Mode <b>Off</b> / Full Scan	Enables higher speed imaging than 60P. Off: Higher speed imaging than 60P is disabled. Full Scan: Enables high-speed imaging at Super 35 frame size.
	Frame Rate Up to 240fps	Sets the frame rate for Slow & Quick Motion shooting (page 43).
<b>Note</b>		
The initial value varies depending on the Codec, Country, Video Format, and RAW Output Format settings.		
<b>Picture Cache Rec</b> Picture cache recording mode settings	Setting On / <b>Off</b>	Turns the picture cache recording function on/off.
	Cache Rec Time <b>0-2sec</b> / 2-4sec / 4-6sec / 6-8sec / 8-10sec / 10-12sec / 12-14sec / 13-15sec	Sets the picture cache recording time, when Picture Cache Rec is set to On.
<b>Simul Rec</b> Simultaneous recording settings	Setting On / <b>Off</b>	Turns the simultaneous recording function on/off and sets the recording destination media.
	Rec Button Set “ <b>Rec Button [SlotA SlotB]</b> <b>Handle Rec Button [SlotA SlotB]</b> ” / “Rec Button [SlotA] Handle Rec Button [SlotB]” / “Rec Button [SlotB] Handle Rec Button [SlotA]”	Assigns the record buttons used to control each recording media.
<b>SDI/HDMI Rec Control</b> SDI/HDMI recording control settings	Setting On / <b>Off</b>	Turns recording start/stop control for an external connected device, using SDI/HDMI signals, on/off.

## Thumbnail Menu

Thumbnail		
Item	Sub-item setting	Description
<b>Display Clip Properties</b> Display clip properties screen		Displays the clip properties screen.
<b>Set Index Picture</b> Clip index picture settings		Sets the index picture of a clip.
<b>Thumbnail View</b> Thumbnail screen settings	Essence Mark Thumbnail <b>All</b> / Rec Start / Shot Mark1 / Shot Mark2 / Shot Mark3 / Shot Mark4 / Shot Mark5 / Shot Mark6 / Shot Mark7 / Shot Mark8 / Shot Mark9 / Shot Mark0	Displays thumbnails of frames with essence marks.
	Clip Thumbnail	Displays thumbnails of recorded clips.
<b>Set Shot Mark</b> Shot mark settings	Add Shot Mark1	Adds Shot Mark1.
	Delete Shot Mark1	Deletes Shot Mark1.
	Add Shot Mark2	Adds Shot Mark2.
	Delete Shot Mark2	Deletes Shot Mark2.
<b>Set Clip Flag</b> Clip flag settings	Add OK	Adds an OK flag.
	Add NG	Adds an NG flag.
	Add KEEP	Adds a Keep flag.
	Delete Clip Flag	Deletes all flags.
<b>Lock/Unlock Clip</b> Clip protection	Select Clip	Selects and locks/unlocks a clip.
	Lock All Clips	Locks all clips.
	Unlock All Clips	Unlocks all clips.
<b>Delete Clip</b> Delete clips	Select Clip	Deletes the selected clip.
	All Clips	Deletes all of the displayed clips.
<b>Filter Clips</b> Filtered clip display settings	OK	Display only clips that have an OK flag.
	NG	Display only clips that have an NG flag.
	KEEP	Display only clips that have a Keep flag.
	None	Display only clips that have no flag.
<b>Customize View</b> Thumbnail screen settings	Thumbnail Caption Date Time / Time Code / Duration / Sequential Number	Switches the information displayed below thumbnails.

## Media Menu

Media		
Item	Sub-item setting	Description
<b>Update Media</b> Update memory cards	Media (A) Execute / Cancel	Updates the management file on the XQD memory card in slot A. Execute: Update card
	Media (B) Execute / Cancel	Updates the management file on the XQD memory card in slot B. Execute: Update card
<b>Format Media</b> Format (initializes) memory cards	Media (A) Execute / Cancel	Initializes the XQD memory card in slot A. Execute: Initialize card
	Media (B) Execute / Cancel	Initializes the XQD memory card in slot B. Execute: Initialize card
	SD Card Execute / Cancel	Initializes the UTILITY SD card. Execute: Initialize card
<b>Clip</b> Clip name settings	Auto Naming <b>Cam ID + Reel# / Title</b>	Sets the method for naming clips. Cam ID + Reel#: Camera ID + Reel Number + Shot Number + Date + randomized string Title: String set using Title Prefix + Clip Number
	Camera ID <b>A</b> to Z	Sets the camera ID when Auto Naming is set to Cam ID + Reel#.
	Reel Number 001 to 999	Sets the numeric part of Reel Number when Auto Naming is set to Cam ID + Reel#.
	Camera Position <b>C / L / R</b>	Sets the Shot Number prefix when Auto Naming is set to Cam ID + Reel#.
	Title Prefix	Sets the title portion of the clip name when Auto Naming is set to Title. (Initial value is a model-specific ID, comprising the last three digits of the serial number.) (The value is entered using the character entry screen (page 56).)
	Number Set <b>0001</b> to 9999	Sets the numeric portion of the clip name when Auto Naming is set to Title.

## File Menu

File		
Item	Sub-item setting	Description
<b>All File</b> Settings related to ALL files.	Load SD Card	Loads an ALL file.
	Execute / Cancel	Execute: Load file
	Save SD Card	Saves an ALL file.
	Execute / Cancel	Execute: Save file
	File ID	Assigns a name to the file.
<b>Scene File</b> Scene file settings	Recall Internal Memory	Loads a scene file from internal memory.
	Execute / Cancel	Execute: Load file
	Store Internal Memory	Saves a scene file in internal memory.
	Execute / Cancel	Execute: Save file
	Load SD Card	Loads a scene file from an SD card.
	Execute / Cancel	Execute: Load file
	Save SD Card	Saves a scene file to an SD card.
	Execute / Cancel	Execute: Save file
	File ID	Assigns a name to the file.
	Scene White Data On / <b>Off</b>	Sets whether to apply the white balance data when loading scene files.
<b>User Menu Item</b> User menu item settings	Load SD Card	Loads User menu settings on an SD card into internal memory.
	Execute / Cancel	Execute: Load settings
	Save SD Card	Saves User menu settings on an SD card.
	Execute / Cancel	Execute: Save settings
	File ID	Displays the File ID specified for the file loaded using Load SD Card. Also sets (edits) the File ID when saving a file using this menu.
<b>User Gamma</b> User gamma file settings	Current Settings	Displays a list of the current user gamma file settings (file names).
	Load SD Card	Loads user gamma settings on an SD card into internal memory.
	Execute / Cancel	Execute: Load gamma
	Reset <b>1 / 2 / 3 / 4 / 5 / All</b> Initial value: 709(800%)	Resets the user gamma files in internal memory to default values. 1 to 5: Reset individual user gamma All: Reset all user gammas
<b>Monitor LUT</b> Monitor LUT file settings	Current Settings	Displays a list of the current monitor LUT file settings (file names).
	Load SD Card	Loads monitor LUT settings on an SD card into internal memory.
	Execute / Cancel	Execute: Load LUT settings
	Reset <b>1 / 2 / 3 / 4 / 5 / 6 / All</b>	Resets the monitor LUT data in internal memory to default values. 1 to 6: Reset individual monitor LUT All: Reset all monitor LUTs



File		
Item	Sub-item setting	Description
<b>Monitor 3D LUT</b> Monitor 3D LUT file settings	Current Settings	Displays a list of the current monitor 3D LUT file settings (file names).
	Load SD Card Execute / Cancel	Loads monitor 3D LUT settings on an SD card into internal memory. Execute: Load 3D LUT settings
	Reset <b>1 / 2 / 3 / 4 / All</b>	Resets the monitor 3D LUT data in internal memory to default values. 1 to 4: Reset individual monitor 3D LUT All: Reset all monitor 3D LUTs
<b>Lens File</b> Lens file settings	White Offset R –99 to +99 ( <b>±0</b> )	Sets the white balance offset R channel correction value for the lens in the lens file.
	White Offset B –99 to +99 ( <b>±0</b> )	Sets the white balance offset B channel correction value for the lens in the lens file.

## System Menu

System		
Item	Sub-item setting	Description
<b>Base Setting</b> Base settings	Shooting Mode <b>Custom</b> / Cine EI	Sets the shooting mode.
	Color Space S-Gamut3.Cine/SLog3 / S-Gamut3/SLog3 / <b>Matrix</b>	Sets the color space.
<b>Codec</b> Codec settings	Select RAW / RAW & XAVC-I / RAW & XAVC-L / RAW & MPEG HD 422 / <b>XAVC-I</b> / XAVC-L / MPEG HD 422	Sets the recording/playback mode.  <b>Note</b> RAW, RAW & XAVC-I, RAW & XAVC-L, and RAW & MPEG HD 422 are displayed when an XDCA-FS7 is connected.
	<b>Rec Format</b> Recording format settings	Video Format Sets the recording format.  • For NTSC systems: When Codec >Select is set to XAVC-I. <b>3840×2160 59.94P</b> 3840×2160 29.97P 3840×2160 23.98P 1920×1080 59.94P 1920×1080 59.94i 1920×1080 29.97P 1920×1080 23.98P When Codec >Select is set to XAVC-L. <b>3840×2160 59.94P</b> 3840×2160 29.97P 3840×2160 23.98P 1920×1080 59.94P 50 1920×1080 59.94P 35 1920×1080 59.94i 50 1920×1080 59.94i 35 1920×1080 59.94i 25 1920×1080 29.97P 50 1920×1080 29.97P 35 1920×1080 23.98P 50 1920×1080 23.98P 35 When Codec >Select is set to MPEG HD422. <b>1920×1080 59.94i 50</b> 1920×1080 29.97P 50 1920×1080 23.98P 50 1280×720 59.94P 50 1280×720 29.97P 50 1280×720 23.98P 50

System		
Item	Sub-item setting	Description
	RAW Output Format	Sets the recording format for an external RAW recorder.
	<ul style="list-style-type: none"> <li>For NTSC systems: When Codec &gt;Select is set to an item that includes RAW. <b>4096x2160 59.94P</b> 4096x2160 29.97P 4096x2160 23.98P 2160x1080 59.94P 2160x1080 29.97P 2160x1080 23.98P</li> <li>For PAL systems: When Codec &gt;Select is set to an item that includes RAW. <b>4096x2160 50P</b> 4096x2160 25P 2160x1080 50P 2160x1080 25P</li> </ul>	
<b>Genlock</b> Genlock settings	Reference <b>Internal</b> / External(HD) / External(SD)	Displays the genlock state. It displays the signal type if genlock is applied. Internal: External genlock not applied. External(HD): Genlock to HD signal. External(SD): Genlock to SD signal.
<b>Assignable Button</b> Assignable button settings	<1> to <6> Off / Marker / Zebra / Peaking / Video Signal Monitor / Focus Magnifier x4/x8 / Focus Magnifier x4 / Focus Magnifier x8 / VF Mode / IRIS / Push Auto Iris / AGC / Push AGC / SHUTTER / Auto Exposure Level / Spotlight / Backlight / ATW / ATW Hold / Push AF/Focus Hold / SteadyShot / Color Bars / User Menu / Rec Lamp / S&Q Motion / Picture Cache Rec / Rec Review / Thumbnail / Shot Mark1 / Shot Mark2 / Clip Flag OK / Clip Flag NG / Clip Flag Keep / DURATION/TC/U-BIT / High/ Low Key	Assigns functions to assignable buttons. Marker: Turns the marker function on/off. Zebra: Turns the Zebra function on/off. Peaking: Turns the peaking function on/off. Video Signal Monitor: Switches the video signal display (histogram, etc.). Focus Magnifier x4/x8: Focus Magnifier x4: Focus Magnifier x8: Turns the focus magnifier function on/off. VF Mode: Switches the viewfinder display between color and B&W. IRIS: Switches the iris function between Auto and Manual. Push Auto Iris: Enables the auto iris function while the button is pressed. AGC: Turns the AGC function on/off.

System	Sub-item setting	Description
Item		
		Push AGC: Enables the AGC function while the button is pressed.
		SHUTTER: Switches the shutter between Auto and Manual.
		Auto Exposure Level: Opens the Auto Exposure Level screen.
		Spotlight: Switches between Spotlight and Standard.
		Backlight: Switches between Backlight and Standard.
		ATW: Turns the ATW function on/off.
		ATW Hold: Pauses ATW function operation.
		Push AF/Focus Hold: Runs the push auto focus function or focus hold function.
		SteadyShot: Switches between Active SteadyShot, SteadyShot, and Off.
		Color Bars: Turns the color bars on/off.
		User Menu: Opens/closes the User menu.
		Rec Lamp: Turns the recording indicator on/off.
		S&Q Motion: Turns Slow & Quick Motion on/off.
		Picture Cache Rec: Turns picture cache recording mode on/off.
		Rec Review: Turns the Rec Review function on/off.
		Thumbnail: Opens/closes the thumbnail screen.
		Shot Mark 1: Runs the Add Shot Mark1 function.
		Shot Mark 2: Runs the Add Shot Mark2 function.
		Clip Flag OK: Runs the Add OK function. Press twice to execute Delete Clip Flag.
		Clip Flag NG: Runs the Add NG function. Press twice to execute Delete Clip Flag.
		Clip Flag Keep: Runs the Add Keep function. Press twice to execute Delete Clip Flag.
		DURATION/TC/U-BIT: Switches between Time Code, Users Bit, and Duration.
		High/Low Key: Switches between High Key, Low Key, and Off.

System		
Item	Sub-item setting	Description
<b>Assignable Dial</b> Assignable dial settings	Assignable Dial Off / ISO/Gain/EI / <b>IRIS</b> / Focus / Audio Input Level	Assigns functions to the assignable dial on the grip remote control. ISO/Gain/EI: Adjusts the gain or EI. IRIS: Adjusts the iris. Focus: Adjusts the focus. Audio Input Level: Adjusts the audio level.
	IRIS Dial (Same settings as Assignable Dial)	Assigns functions to the IRIS dial.
	Assignable Dial Direction <b>Normal</b> / Opposite	Sets the direction of rotation of the assignable dial on the grip remote control. Normal: Turn in forward direction. Opposite: Turn in opposite direction.
	IRIS Dial Direction <b>Normal</b> / Opposite	Sets the direction of rotation of the IRIS dial. Normal: Turn in forward direction. Opposite: Turn in opposite direction.
<b>Rec Lamp</b> Recording indicator settings	Rec Lamp <b>On</b> / Off	Turns the recording indicator on/off.
<b>Fan Control</b> Fan control mode settings	Fan Control Mode <b>Auto</b> / Minimum / Off in Rec	Sets the control mode of the camcorder fan. <b>Note</b> Even when “Off in Rec” is selected, the fan will operate if the internal temperature of the camcorder rises above a certain value.
<b>HOLD Switch Setting</b> Hold switch settings	with Rec Button <b>On</b> / Off	Sets whether or not to lock the recording button.
	with Hand Grip Remote <b>On</b> / Off	Sets whether to lock operation of the grip remote control.
<b>Lens</b> Lens settings	Zoom Ring Direction <b>Left(W)/Right(T)</b> / Right(W)/ Left(T)	Sets the direction of zoom ring operation. <b>Note</b> Enabled only when using an E-mount lens that supports zoom ring direction switching.
	Distortion Comp. Auto / <b>Off</b>	Turns automatic distortion compensation on/off. <b>Notes</b> <ul style="list-style-type: none"> <li>• Not available in picture cache recording mode or when recording.</li> <li>• Distortion compensation is not applied during QFHD recording.</li> </ul>
<b>Language</b> Language settings	Select	Sets the display language. SET: Set language.

System		
Item	Sub-item setting	Description
<b>Clock Set</b> Internal clock settings	Time Zone UTC 12:00 Kwajalein to UTC +14:00	Sets the time difference from UTC in 30-minute units.
	Date Mode <b>YYMMDD</b> / MMDDYY / DDMMYY	Selects the display format for dates. YYMMDD: Year, month, day MMDDYY: Month, day, year DDMMYY: Day, month, year
	12H/24H 12H / <b>24H</b>	Selects the clock display format. 12H: 12-hour mode 24H: 24-hour mode
	Date	Sets the current date. SET: Set the value.
	Time	Sets the current time. SET: Set the value.
	<b>Country</b> Region settings	NTSC/PAL Area <b>NTSC Area</b> / PAL Area
<b>Hours Meter</b> Hours meter settings	Hours (System)	Displays the accumulated hours of use (cannot be reset).
	Hours (Reset)	Displays the accumulated hours of use (can be reset).
	Reset Execute / Cancel	Resets the Hours (Reset) display to 0. Execute: Reset
<b>Basic Authentication</b> Basic network authentication settings	User Name <b>(admin)</b>	Sets a desired user name (1 to 16 alphanumeric characters). SET: Set the value.
	Password <b>(pxw-fs7)</b>	Sets a password (1 to 16 alphanumeric characters). SET: Set the value.
<b>Wi-Fi</b> Wireless LAN connection settings	Wi-Fi Enable / <b>Disable</b>	Selects whether to enable or disable Wi-Fi connection.
	SSID & Password	Displays the SSID and password.
	Wi-Fi Direct Connection Execute / Cancel	Starts a “Wi-Fi Direct” network connection. Execute: Connect
	Client	Displays information about the connected client device (model name and MAC address).
	IP Address 192.168.1.1	Displays the IP address of the camcorder. <b>Note</b> Not displayed when using the CBK-WA100.
	Subnet Mask 255.255.0.0	Displays the subnet mask. <b>Note</b> Not displayed when using the CBK-WA100.
	MAC Address	Displays the MAC address of the Wi-Fi module attached to the camcorder.
	Regenerate Password Execute / Cancel	Creates a new password. Execute: Run
	<b>GPS</b> GPS settings	GPS <b>On</b> / Off <b>Note</b> The GPS module is built into the handle.

System		
Item	Sub-item setting	Description
<b>IR Remote</b> Remote control settings	Setting <b>On</b> / Off	Enables/disables control from the supplied infrared remote control.
<b>Camera Battery Alarm</b> Battery low-voltage alarm settings	Low BATT 5% / <b>10%</b> / 15% / ... / 45% / 50%	Sets the remaining battery level to display a battery low-voltage alarm (5% increments).
	BATT Empty <b>3%</b> to 7%	Sets the remaining battery level to display a battery empty alarm.
<b>Camera DC IN Alarm</b> Input voltage alarm settings	DC Low Voltage1 <b>11.5 V</b> to 17.0 V	Sets the voltage to display a DC IN low input voltage alarm.
	DC Low Voltage2 <b>11.0 V</b> to 14.0 V	Sets the voltage to display a DC IN insufficient input voltage alarm.
<b>Ext. Unit Battery Alarm</b> XDCA-FS7 battery settings	Near End:Info Battery <b>5%</b> to 100%	Sets the remaining battery level to display a Info-Lithium battery low-voltage alarm (5% increments).
	End:Info Battery <b>0%</b> to 5%	Sets the remaining battery level to display a Info-Lithium battery end alarm and to stop media access.
	Near End:Sony Battery <b>11.5V</b> to 17.0V	Sets the remaining battery level to display a battery low-voltage alarm for a non Info-Lithium battery.
	End:Sony Battery <b>11.0V</b> to 11.5V	Sets the remaining battery level to display a battery end alarm for a non Info-Lithium battery and to stop media access.
	Near End:Other Battery 11.5V to 17.0V ( <b>11.8V</b> )	Sets the remaining battery level to display a battery low-voltage alarm for an Anton/Bauer battery.
	End:Other Battery <b>11.0V</b> to 14.0V	Sets the remaining battery level to display a battery end alarm for an Anton/Bauer battery and to stop media access.
	Detected Battery	Displays the type of battery connected to the XDCA-FS7. If a battery is connected to the XDCA-FS7, "Info Battery," "Sony Battery," or "Other Battery" is displayed. If a DC source is connected, "DC IN" is displayed. If powered by a battery or DC source connected to the camcorder, " --- " is displayed.
<b>Ext. Unit DC IN Alarm</b> XDCA-FS7 input voltage alarm settings	DC Low Voltage1 <b>11.5V</b> to 17.0V	Sets the voltage to display a DC IN low input voltage alarm.
	DC Low Voltage2 <b>11.0V</b> to 14.0V	Sets the voltage to display a DC IN insufficient input voltage alarm.
<b>All Reset</b> Reset factory defaults	Reset Execute / Cancel	Resets all settings to their factory defaults. Execute: Reset
<b>APR</b> Run APR	APR Execute / Cancel	Runs APR (Automatic Pixel Restoration) for image sensor auto adjustment. Execute: Run
<b>Note</b>		
Always attach the lens cap before running APR.		
<b>Camera Config</b> Down-converter output settings	HD/2K Modulation <b>High</b> / Low	Sets the down-converter output bandwidth for conversion to HD and 2K

System		
Item	Sub-item setting	Description
<b>Version</b> Display version	Number x.xx	Displays the software version of the camcorder.
	Version Up Execute / Cancel	Upgrades the camcorder.* Execute: Run * Upgrading updates the camcorder software.
	Ext. Unit Version Number x.xx	Displays the software version of the XDCA-FS7.
	Ext. Unit Version Up Execute / Cancel	Upgrades the XDCA-FS7.* Execute: Run * Upgrading updates the XDCA-FS7 software.



## External Device Connection

# Connecting External Monitors and Recording Devices

To display recorded/playback pictures on an external monitor, select the camcorder output signal and use an appropriate cable for the monitor to be connected.

You can also connect recording devices, such as a VTR, and record the output signal from the camcorder.

You can display the same information that is visible in the viewfinder, such as status information and menus, on an external monitor. Set Output Display (*page 71*) in the Video menu to “On” for the corresponding type of signal to output to the monitor.

---

### SDI OUT connector (BNC type)

---

Turn the output on/off and set the output format using the Video menu (*page 70*).

Use a commercially available 75  $\Omega$  coaxial cable for connection.

#### Note

Check that the connection between the camcorder and the external device is grounded before turning the devices on.

(It is recommended that the camcorder and external device be turned on after connecting the 75  $\Omega$  coaxial cable.)

If the external device must be connected to the camcorder while the camcorder is on, connect the 75  $\Omega$  coaxial cable to the external device first and then connect it to the camcorder.

### To start recording on the camcorder and external device simultaneously

With SDI signal output enabled, set SDI/HDMI Rec Control (*page 77*) >Setting in the Recording menu to “On” to enable output of a REC trigger signal to the external device connected to the SDI OUT connector. This will synchronize recording on the external device with the camcorder.

#### Note

If a connected external device does not support a REC trigger signal, the device cannot be operated.

---

### HDMI OUT connector (Type A connector)

---

Turn the output on/off and set the output format using the Video menu (*page 70*).

Use a commercially available high-speed HDMI cable for connection.

Select the type of the connected device using HDMI Target Device (*page 104*) in the Video menu.

---

### RAW OUT connector (BNC type)

---

Attaching an XDCA-FS7 Extension Unit to the camcorder provides support for an external RAW recorder, such as the AXS-R5, to be connected to the RAW OUT connector of the XDCA-FS7 (*page 31*).

## External Synchronization

When shooting using multiple camcorder units, the camcorders can be synchronized to a specific reference signal or timecodes synchronized via the Genlock connector of the XDCA-FS7 units (*page 12*) attached to the camcorders.

### Note

The camcorder battery pack cannot be used when an XDCA-FS7 unit is attached to the camcorder. You must attach a battery pack to the XDCA-FS7 or connect an external power supply.

### Synchronizing the phase of the video signals (genlock)

Enable genlock by supplying a reference signal to the Genlock connector (*page 12*) of the XDCA-FS7 units connected to the camcorders. The reference signals that can be used vary depending on the frame rate of the selected recording format.

#### For NTSC Area

Frame rate of recording format	Valid reference signals
59.94P	1920 × 1080 59.94i 720 × 486 59.94i 1280 × 720 59.94P
29.97P	1920 × 1080 59.94i 720 × 486 59.94i
23.98P	1920 × 1080 47.95i (23.98PsF)
59.94i	1920 × 1080 59.94i 720 × 486 59.94i

#### For PAL Area

Frame rate of recording format	Valid reference signals
50P	1920 × 1080 50i 720 × 576 50i 1280 × 720 50P
25P	1920 × 1080 50i 720 × 576 50i
50i	1920 × 1080 50i 720 × 576 50i

### Notes

- If the selected recording format is 1280×720 60P, you must supply both a video signal and a time signal.
- If the reference signal is unstable, genlock cannot be achieved.
- The subcarrier is not synchronized.

### Locking the timecode to other devices

Set the unit that supplies the timecode to a mode in which the timecode output keeps running (such as Free Run or Clock).

- 1 Set Timecode in the TC/UB menu as follows.**  
Mode: Preset  
Run: Free Run
- 2 Press the assignable button (*page 42*) assigned with the DURATION/TC/ U-BIT function to display the timecode on the screen.**
- 3 Check that the TC IN/OUT switch (*page 12*) on the XDCA-FS7 is set to the IN position, and supply an HD or SD reference video signal and a timecode synchronized to the video signal to the Genlock and TC IN/OUT connectors, respectively.**

The timecode generator of the camcorder acquires lock with the reference timecode, and “EXT-LK” appears on the screen.

Once about ten seconds have elapsed after the timecode locks, the external lock state is maintained even if the external reference timecode source is disconnected.

### Notes

- Check that the supplied reference timecode and the reference video signal are in a phase relationship that complies with the SMPTE timecode standard.
- When operating with external lock, the timecode instantly acquires lock with the external timecode and the external timecode value appears in the data display area. However, do not start recording immediately. Wait for a few seconds until the timecode generator stabilizes before recording.
- If the frequency of the reference video signal and the frame frequency on the camcorder are not the same, lock cannot be acquired and the camcorder will not operate properly. If this occurs, the timecode will not acquire successful lock with the external timecode.

- If the external timecode source is disconnected, the timecode may shift by one frame per hour with respect to the reference timecode.

#### **To release external lock**

Change the Timecode setting in the TC/UB menu, or turn the camcorder off.

External lock is also released if you start recording in Slow & Quick Motion mode.

---

### **Synchronizing the timecode of another device with the timecode of the camcorder**

---

Set the unit that supplies the timecode to a mode in which the timecode output keeps running (such as Free Run or Clock).

- 1 Set the timecode of the camcorder using the Timecode (page 76) in the TC/UB menu.**
- 2 Check that the TC IN/OUT switch (page 12) is set to the OUT position, and connect the TC IN/OUT connector and Genlock connector (page 12) to the timecode input and reference signal input, respectively, of the device you want to synchronize.**

## **Managing/Editing Clips using a Computer**

### **Connecting using a USB Cable**

---

#### **Using an XQD card reader (option)**

---

Connect an MRW-E80 XQD Card Reader (option) using a USB cable, and insert a memory card in the slot. The memory card is recognized as a computer extension drive.

---

#### **Using mass storage mode**

---

Connect the camcorder using a USB cable, and insert a memory card in the slot. The memory card is recognized as a computer extension drive.

- 1 Turn the camcorder POWER switch to the ON position.**

A message appears on the screen or viewfinder asking whether to enable USB connection.

#### **Note**

The USB connection confirmation message is not displayed while another confirmation message or progress message is displayed, for example, when formatting or restoring an XQD memory card. The confirmation message is displayed when the formatting or restoring execution ends. The USB confirmation message is also not displayed when the clip properties screen is displayed. The message is displayed when processing ends or when you return to the thumbnail screen.

- 2 Turn the SEL/SET dial and select Execute.**

- 3 On Windows, check that the card is added as a removable disk in the “My Computer” window.**  
**On Macintosh, check that a folder called “NO NAME” or “Untitled” (editable) is created on the Desktop.**

#### **Notes**

- Do not perform the following operations if the access lamp is lit red.
  - Turning the power off
  - Disconnecting the power cord
  - Removing the XQD memory card
  - Disconnecting the USB cable
- Operation is not guaranteed to work on all computers.

---

#### **Using nonlinear editing systems**

---

In a nonlinear editing system, editing software (option) that supports the formats recorded by the camcorder is required.

Use dedicated application software to save the clips you want to edit on the HDD of the computer beforehand.

## Usage Precautions

The fan is a consumable part that will need periodic replacement.

When operating at room temperature, a normal replacement cycle will be about 5 years.

However, this replacement cycle represents only a general guideline and does not imply that the life expectancy of this part is guaranteed. For details on parts replacement, contact your dealer.

If the unit is suddenly taken from a cold to a warm location, or if ambient temperature suddenly rises, moisture may form on the outer surface of the unit and/or inside of the unit. This is known as condensation. If condensation occurs, turn off the unit and wait until the condensation clears before operating the unit. Operating the unit while condensation is present may damage the unit.

The LCD panel fitted to this unit is manufactured with high precision technology, giving a functioning pixel ratio of at least 99.99%. Thus a very small proportion of pixels may be “stuck”, either always off (black), always on (red, green, or blue), or flashing. In addition, over a long period of use, because of the physical characteristics of the liquid crystal display, such “stuck” pixels may appear spontaneously. These problems are not a malfunction. Note that any such problems have no effect on recorded data.

The battery terminal of this unit (the connector for battery packs and AC adaptors) is a consumable part.

Power may not be supplied to the unit properly if the pins of the battery terminal are bent or deformed by shock or vibrations, or if they become corroded due to prolonged outdoor use. Periodic inspections are recommended to keep the unit working properly and to prolong its usable lifetime.

Contact a Sony service or sales representative for more information about inspections.

### **About the built-in rechargeable battery**

The camcorder has a built-in rechargeable battery for storing the date, time, and other settings even when the camcorder is turned off. The rechargeable battery will be fully discharged in about **3 months** if the AC adaptor is not connected or the camcorder is used without the battery pack attached. Use your camcorder after charging the battery.

However, even if the built-in rechargeable battery is not charged, the camcorder operation will not be affected as long as you are not recording the time and date.

# Output Formats and Limitations

## Video Formats and Output Signals

Factory default settings are shown in bold (for example, **2048×1080P (Level A)**).

### SDI OUT connector output formats

When Country >NTSC/PAL Area in the System menu is set to NTSC Area

Recording format settings (Rec Format >RAW Output Format and Video Format in the System menu)	SDI/HDMI output settings (Output Format >SDI and HDMI in the Video menu)		SDI output signal
	SDI	HDMI	
<b>RAW Output Format</b> 4096×2160 59.94P <b>Video Format (fixed value)</b> 1920×1080 59.94P	<b>2048×1080P (Level A)</b>	–	2048×1080 59.94P Level-A
	2048×1080P (Level B)	–	2048×1080 59.94P Level-B
	1920×1080P (Level A)	1920×1080P	1920×1080 59.94P Level-A
	1920×1080P (Level B)	–	1920×1080 59.94P Level-B
	1920×1080i	1920×1080i	1920×1080 59.94i
<b>RAW Output Format</b> 4096×2160 59.94P <b>Video Format (fixed value)</b> 1280×720 59.94P	<b>2048×1080P (Level A)</b>	–	2048×1080 59.94P Level-A
	2048×1080P (Level B)	–	2048×1080 59.94P Level-B
	1920×1080P (Level A)	1920×1080P	1920×1080 59.94P Level-A
	1920×1080P (Level B)	–	1920×1080 59.94P Level-B
	1280×720P	1280×720P	1280×720 59.94P
<b>RAW Output Format</b> – <b>Video Format</b> 3840×2160 59.94P	–	4096×2160P	No output
	–	<b>3840×2160P</b>	No output
	1920×1080P (Level A)	1920×1080P	1920×1080 59.94P Level-A
	1920×1080P (Level B)	–	1920×1080 59.94P Level-B
<b>RAW Output Format</b> 2048×1080 59.94P <b>Video Format (fixed value)</b> 1920×1080 59.94P	<b>2048×1080P (Level A)</b>	–	2048×1080 59.94P Level-A
	2048×1080P (Level B)	–	2048×1080 59.94P Level-B
	1920×1080P (Level A)	1920×1080P	1920×1080 59.94P Level-A
	1920×1080P (Level B)	–	1920×1080 59.94P Level-B
	1920×1080i	1920×1080i	1920×1080 59.94i

Recording format settings (Rec Format >RAW Output Format and Video Format in the System menu)	SDI/HDMI output settings (Output Format >SDI and HDMI in the Video menu)		SDI output signal
	SDI	HDMI	
<b>RAW Output Format</b> 2048×1080 59.94P <b>Video Format (fixed value)</b> 1280×720 59.94P	<b>2048×1080P (Level A)</b>	–	2048×1080 59.94P Level-A
	2048×1080P (Level B)	–	2048×1080 59.94P Level-B
	1920×1080P (Level A)	1920×1080P	1920×1080 59.94P Level-A
	1920×1080P (Level B)	–	1920×1080 59.94P Level-B
	1280×720P	1280×720P	1280×720 59.94P
<b>RAW Output Format</b> – <b>Video Format</b> 1920×1080 59.94P	2048×1080P (Level A)	–	2048×1080 59.94P Level-A
	2048×1080P (Level B)	–	2048×1080 59.94P Level-B
	<b>1920×1080P (Level A)</b>	<b>1920×1080P</b>	1920×1080 59.94P Level-A
	1920×1080P (Level B)	–	1920×1080 59.94P Level-B
	1920×1080i	1920×1080i	1920×1080 59.94i
	–	720×480i	No output
	–	720×480P	No output
<b>RAW Output Format</b> – <b>Video Format</b> 1920×1080 59.94i	<b>1920×1080i</b>	<b>1920×1080i</b>	1920×1080 59.94i
	–	720×480i	No output
	–	720×480P	No output
<b>RAW Output Format</b> – <b>Video Format</b> 1280×720 59.94P	<b>1280×720P</b>	<b>1280×720P</b>	1280×720 59.94P
	–	720×480i	No output
	–	720×480P	No output
<b>RAW Output Format</b> 4096×2160 29.97P <b>Video Format (fixed value)</b> 1920×1080 29.97P	<b>2048×1080PsF</b>	–	2048×1080 29.97PsF
	1920×1080PsF	1920×1080i	1920×1080 29.97PsF
<b>RAW Output Format</b> – <b>Video Format</b> 3840×2160 29.97P	–	4096×2160P	No output
	–	<b>3840×2160P</b>	No output
	1920×1080PsF	1920×1080i	1920×1080 29.97PsF
<b>RAW Output Format</b> 2048×1080 29.97P <b>Video Format (fixed value)</b> 1920×1080 29.97P	<b>2048×1080PsF</b>	–	2048×1080 29.97PsF
	1920×1080PsF	1920×1080i	1920×1080 29.97PsF
<b>RAW Output Format</b> – <b>Video Format</b> 1920×1080 29.97P	2048×1080PsF	–	2048×1080 29.97PsF
	<b>1920×1080PsF</b>	<b>1920×1080i</b>	1920×1080 29.97PsF
	–	720×480i	No output
<b>RAW Output Format</b> – <b>Video Format</b> 1280×720 29.97P	<b>1280×720P</b>	<b>1280×720P</b>	1280×720 59.94P (2-2RP)
	–	720×480i	No output

Recording format settings (Rec Format >RAW Output Format and Video Format in the System menu)	SDI/HDMI output settings (Output Format >SDI and HDMI in the Video menu)		SDI output signal
	SDI	HDMI	
<b>RAW Output Format</b> 4096×2160 23.98P	<b>2048×1080PsF</b>	–	2048×1080 23.98PsF
	1920×1080PsF	–	1920×1080 23.98PsF
<b>Video Format (fixed value)</b> 1920×1080 23.98P	–	1920×1080P	No output
<b>RAW Output Format</b> –	–	4096×2160P	No output
	–	<b>3840×2160P</b>	No output
<b>Video Format</b> 3840×2160 23.98P	1920×1080PsF	–	1920×1080 23.98PsF
–	–	1920×1080P	No output
<b>RAW Output Format</b> 2048×1080 23.98P	<b>2048×1080PsF</b>	–	2048×1080 23.98PsF
	1920×1080PsF	–	1920×1080 23.98PsF
<b>Video Format (fixed value)</b> 1920×1080 23.98P	–	1920×1080P	No output
<b>RAW Output Format</b> –	2048×1080PsF	–	2048×1080 23.98PsF
	<b>1920×1080PsF</b>	–	1920×1080 23.98PsF
<b>Video Format</b> 1920×1080 23.98P	–	1920×1080P	No output
–	1920×1080i (2-3PD)	1920×1080i (2-3PD)	1920×1080 59.94i (2-3PD)
–	–	720×480i (2-3PD)	No output
<b>RAW Output Format</b> –	<b>1280×720P (2-3PD)</b>	<b>1280×720P (2-3PD)</b>	1280×720 59.94P (2-3PD)
	–	720×480i (2-3PD)	No output
<b>Video Format</b> 1280×720 23.98P	–	–	–



When Country >NTSC/PAL Area in the System menu is set to PAL Area

Recording format settings (Rec Format >RAW Output Format and Video Format in the System menu)	SDI/HDMI output settings (Output Format >SDI and HDMI in the Video menu)		SDI output signal
	SDI	HDMI	
<b>RAW Output Format</b> 4096×2160 50P <b>Video Format (fixed value)</b> 1920×1080 50P	<b>2048×1080P (Level A)</b>	–	2048×1080 50P Level-A
	2048×1080P (Level B)	–	2048×1080 50P Level-B
	1920×1080P (Level A)	1920×1080P	1920×1080 50P Level-A
	1920×1080P (Level B)	–	1920×1080 50P Level-B
	1920×1080i	1920×1080i	1920×1080 50i
<b>RAW Output Format</b> 4096×2160 50P <b>Video Format (fixed value)</b> 1280×720 50P	<b>2048×1080P (Level A)</b>	–	2048×1080 50P Level-A
	2048×1080P (Level B)	–	2048×1080 50P Level-B
	1920×1080P (Level A)	1920×1080P	1920×1080 50P Level-A
	1920×1080P (Level B)	–	1920×1080 50P Level-B
	1280×720P	1280×720P	1280×720 50P
<b>RAW Output Format</b> – <b>Video Format</b> 3840×2160 50P	–	4096×2160P	No output
	–	<b>3840×2160P</b>	No output
	1920×1080P (Level A)	1920×1080P	1920×1080 50P Level-A
	1920×1080P (Level B)	–	1920×1080 50P Level-B
	1920×1080i	1920×1080i	1920×1080 50i
<b>RAW Output Format</b> 2048×1080 50P <b>Video Format (fixed value)</b> 1920×1080 50P	<b>2048×1080P (Level A)</b>	–	2048×1080 50P Level-A
	2048×1080P (Level B)	–	2048×1080 50P Level-B
	1920×1080P (Level A)	1920×1080P	1920×1080 50P Level-A
	1920×1080P (Level B)	–	1920×1080 50P Level-B
	1920×1080i	1920×1080i	1920×1080 50i
<b>RAW Output Format</b> 2048×1080 50P <b>Video Format (fixed value)</b> 1280×720 50P	<b>2048×1080P (Level A)</b>	–	2048×1080 50P Level-A
	2048×1080P (Level B)	–	2048×1080 50P Level-B
	1920×1080P (Level A)	1920×1080P	1920×1080 50P Level-A
	1920×1080P (Level B)	–	1920×1080 50P Level-B
	1280×720P	1280×720P	1280×720 50P

Recording format settings (Rec Format >RAW Output Format and Video Format in the System menu)	SDI/HDMI output settings (Output Format >SDI and HDMI in the Video menu)		SDI output signal
	SDI	HDMI	
<b>RAW Output Format</b> –	2048×1080P (Level A)	–	2048×1080 50P Level-A
<b>Video Format</b> 1920×1080 50P	2048×1080P (Level B)	–	2048×1080 50P Level-B
	<b>1920×1080P (Level A)</b>	<b>1920×1080P</b>	1920×1080 50P Level-A
	1920×1080P (Level B)	–	1920×1080 50P Level-B
	1920×1080i	1920×1080i	1920×1080 50i
	–	720×576i	No output
	–	720×576P	No output
<b>RAW Output Format</b> –	<b>1920×1080i</b>	<b>1920×1080i</b>	1920×1080 50i
<b>Video Format</b> 1920×1080 50i	–	720×576i	No output
	–	720×576P	No output
<b>RAW Output Format</b> –	<b>1280×720P</b>	<b>1280×720P</b>	1280×720 50P
<b>Video Format</b> 1280×720 50P	–	720×576i	No output
	–	720×576P	No output
<b>RAW Output Format</b> 4096×2160 25P	<b>2048×1080PsF</b>	–	2048×1080 25PsF
<b>Video Format (fixed value)</b> 1920×1080 25P	1920×1080PsF	1920×1080i	1920×1080 25PsF
<b>RAW Output Format</b> –	–	4096×2160P	No output
<b>Video Format</b> 3840×2160 25P	–	<b>3840×2160P</b>	No output
	1920×1080PsF	1920×1080i	1920×1080 25PsF
<b>RAW Output Format</b> 2048×1080 25P	<b>2048×1080PsF</b>	–	2048×1080 25PsF
<b>Video Format (fixed value)</b> 1920×1080 25P	1920×1080PsF	1920×1080i	1920×1080 25PsF
<b>RAW Output Format</b> –	2048×1080PsF	–	2048×1080 25PsF
<b>Video Format</b> 1920×1080 25P	<b>1920×1080PsF</b>	<b>1920×1080i</b>	1920×1080 25PsF
	–	720×576i	No output
<b>RAW Output Format</b> –	<b>1280×720P</b>	<b>1280×720P</b>	1280×720 50P (2-2RP)
<b>Video Format</b> 1280×720 25P	–	720×576i	No output

## HDMI OUT connector output formats

When Country >NTSC/PAL Area in the System menu is set to NTSC Area

Recording format settings (Rec Format >RAW Output Format and Video Format in the System menu)	SDI/HDMI output settings (Output Format >SDI and HDMI in the Video menu)		HDMI output signal
	SDI	HDMI	
<b>RAW Output Format</b> 4096×2160 59.94P <b>Video Format (fixed value)</b> 1920×1080 59.94P	<b>2048×1080P (Level A)</b>	–	No output
	2048×1080P (Level B)	–	No output
	1920×1080P (Level A)	1920×1080P	1920×1080 59.94P
	1920×1080P (Level B)	–	No output
	1920×1080i	1920×1080i	1920×1080 59.94i
<b>RAW Output Format</b> 4096×2160 59.94P <b>Video Format (fixed value)</b> 1280×720 59.94P	<b>2048×1080P (Level A)</b>	–	No output
	2048×1080P (Level B)	–	No output
	1920×1080P (Level A)	1920×1080P	1920×1080 59.94P
	1920×1080P (Level B)	–	No output
	1280×720P	1280×720P	1280×720 59.94P
<b>RAW Output Format</b> – <b>Video Format</b> 3840×2160 59.94P	–	4096×2160P	4096×2160 59.94P
	–	<b>3840×2160P</b>	3840×2160 59.94P
	1920×1080P (Level A)	1920×1080P	1920×1080 59.94P
	1920×1080P (Level B)	–	No output
<b>RAW Output Format</b> 2048×1080 59.94P <b>Video Format (fixed value)</b> 1920×1080 59.94P	1920×1080i	1920×1080i	1920×1080 59.94i
	<b>2048×1080P (Level A)</b>	–	No output
	2048×1080P (Level B)	–	No output
	1920×1080P (Level A)	1920×1080P	1920×1080 59.94P
	1920×1080P (Level B)	–	No output
<b>RAW Output Format</b> 2048×1080 59.94P <b>Video Format (fixed value)</b> 1280×720 59.94P	1920×1080i	1920×1080i	1920×1080 59.94i
	<b>2048×1080P (Level A)</b>	–	No output
	2048×1080P (Level B)	–	No output
	1920×1080P (Level A)	1920×1080P	1920×1080 59.94P
	1920×1080P (Level B)	–	No output
<b>RAW Output Format</b> 2048×1080 59.94P <b>Video Format (fixed value)</b> 1280×720 59.94P	1280×720P	1280×720P	1280×720 59.94P

Recording format settings (Rec Format >RAW Output Format and Video Format in the System menu)	SDI/HDMI output settings (Output Format >SDI and HDMI in the Video menu)		HDMI output signal
	SDI	HDMI	
<b>RAW Output Format</b> –	2048×1080P (Level A)	–	No output
<b>Video Format</b> 1920×1080 59.94P	2048×1080P (Level B)	–	No output
	<b>1920×1080P (Level A)</b>	<b>1920×1080P</b>	1920×1080 59.94P
	1920×1080P (Level B)	–	No output
	1920×1080i	1920×1080i	1920×1080 59.94i
	–	720×480i	720×480 59.94i
	–	720×480P	720×480 59.94P
<b>RAW Output Format</b> –	<b>1920×1080i</b>	<b>1920×1080i</b>	1920×1080 59.94i
<b>Video Format</b> 1920×1080 59.94i	–	720×480i	720×480 59.94i
	–	720×480P	720×480 59.94P
<b>RAW Output Format</b> –	<b>1280×720P</b>	<b>1280×720P</b>	1280×720 59.94P
<b>Video Format</b> 1280×720 59.94P	–	720×480i	720×480 59.94i
	–	720×480P	720×480 59.94P
<b>RAW Output Format</b> 4096×2160 29.97P	<b>2048×1080PsF</b>	–	No output
<b>Video Format (fixed value)</b> 1920×1080 29.97P	1920×1080PsF	1920×1080i	1920×1080 29.97PsF
<b>RAW Output Format</b> –	–	4096×2160P	4096×2160 29.97P
<b>Video Format</b> 3840×2160 29.97P	–	<b>3840×2160P</b>	3840×2160 29.97P
	1920×1080PsF	1920×1080i	1920×1080 29.97PsF
<b>RAW Output Format</b> 2048×1080 29.97P	<b>2048×1080PsF</b>	–	No output
<b>Video Format (fixed value)</b> 1280×720 29.97P	1280×720P	1280×720P	1280×720 59.94P (2-2RP)
<b>RAW Output Format</b> –	2048×1080PsF	–	No output
<b>Video Format</b> 1920×1080 29.97P	<b>1920×1080PsF</b>	<b>1920×1080i</b>	1920×1080 29.97PsF
	–	720×480i	720×480 59.94i (PsF)
<b>RAW Output Format</b> –	<b>1280×720P</b>	<b>1280×720P</b>	1280×720 59.94P (2-2RP)
<b>Video Format</b> 1280×720 29.97P	–	720×480i	720×480 59.94i (PsF)
<b>RAW Output Format</b> 4096×2160 23.98P	<b>2048×1080PsF</b>	–	No output
<b>Video Format (fixed value)</b> 1920×1080 23.98P	1920×1080PsF	–	No output
	–	1920×1080P	1920×1080 23.98P (Pure)
<b>RAW Output Format</b> –	–	4096×2160P	4096×2160 23.98P
<b>Video Format</b> 3840×2160 23.98P	–	<b>3840×2160P</b>	3840×2160 23.98P
	1920×1080PsF	–	No output
	–	1920×1080P	1920×1080 23.98P (Pure)

Recording format settings (Rec Format >RAW Output Format and Video Format in the System menu)	SDI/HDMI output settings (Output Format >SDI and HDMI in the Video menu)		HDMI output signal
	SDI	HDMI	
<b>RAW Output Format</b> 2048×1080 23.98P	<b>2048×1080PsF</b>	–	No output
	1920×1080PsF	–	No output
<b>Video Format (fixed value)</b> 1920×1080 23.98P	–	1920×1080P	1920×1080 23.98P (Pure)
<b>RAW Output Format</b> – <b>Video Format</b> 1920×1080 23.98P	2048×1080PsF	–	No output
	<b>1920×1080PsF</b>	–	No output
	–	1920×1080P	1920×1080 23.98P (Pure)
	1920×1080i (2-3PD)	1920×1080i (2-3PD)	1920×1080 59.94i (2-3PD)
–	720×480i (2-3PD)	720×480 59.94i (2-3PD)	
<b>RAW Output Format</b> – <b>Video Format</b> 1280×720 23.98P	<b>1280×720P (2-3PD)</b>	<b>1280×720P (2-3PD)</b>	1280×720 59.94P (2-3PD)
	–	720×480i (2-3PD)	720×480 59.94i

When Country >NTSC/PAL Area in the System menu is set to PAL Area

Recording format settings (Rec Format >RAW Output Format and Video Format in the System menu)	SDI/HDMI output settings (Output Format >SDI and HDMI in the Video menu)		HDMI output signal
	SDI	HDMI	
<b>RAW Output Format</b> 4096×2160 50P <b>Video Format (fixed value)</b> 1920×1080 50P	<b>2048×1080P (Level A)</b>	–	No output
	2048×1080P (Level B)	–	No output
	1920×1080P (Level A)	1920×1080P	1920×1080 50P
	1920×1080P (Level B)	–	No output
	1920×1080i	1920×1080i	1920×1080 50i
<b>RAW Output Format</b> 4096×2160 50P <b>Video Format (fixed value)</b> 1280×720 50P	<b>2048×1080P (Level A)</b>	–	No output
	2048×1080P (Level B)	–	No output
	1920×1080P (Level A)	1920×1080P	1920×1080 50P
	1920×1080P (Level B)	–	No output
	1280×720P	1280×720P	1280×720 50P
<b>RAW Output Format</b> – <b>Video Format</b> 3840×2160 50P	–	4096×2160P	4096×2160 50P
	–	<b>3840×2160P</b>	3840×2160 50P
	1920×1080P (Level A)	1920×1080P	1920×1080 50P
	1920×1080P (Level B)	–	No output
	1920×1080i	1920×1080i	1920×1080 50i
<b>RAW Output Format</b> 2048×1080 50P <b>Video Format (fixed value)</b> 1920×1080 50P	<b>2048×1080P (Level A)</b>	–	No output
	2048×1080P (Level B)	–	No output
	1920×1080P (Level A)	1920×1080P	1920×1080 50P
	1920×1080P (Level B)	–	No output
	1920×1080i	1920×1080i	1920×1080 50i
<b>RAW Output Format</b> 2048×1080 50P <b>Video Format (fixed value)</b> 1280×720 50P	<b>2048×1080P (Level A)</b>	–	No output
	2048×1080P (Level B)	–	No output
	1920×1080P (Level A)	1920×1080P	1920×1080 50P
	1920×1080P (Level B)	–	No output
	1280×720P	1280×720P	1280×720 50P

Recording format settings (Rec Format >RAW Output Format and Video Format in the System menu)	SDI/HDMI output settings (Output Format >SDI and HDMI in the Video menu)		HDMI output signal
	SDI	HDMI	
<b>RAW Output Format</b> –	2048×1080P (Level A)	–	No output
<b>Video Format</b> 1920×1080 50P	2048×1080P (Level B)	–	No output
	<b>1920×1080P (Level A)</b>	<b>1920×1080P</b>	1920×1080 50P
	1920×1080P (Level B)	–	No output
	1920×1080i	1920×1080i	1920×1080 50i
	–	720×576i	720×576 50i
	–	720×576P	720×576 50P
<b>RAW Output Format</b> –	<b>1920×1080i</b>	<b>1920×1080i</b>	1920×1080 50i
<b>Video Format</b> 1920×1080 50i	–	720×576i	720×576 50i
	–	720×576P	720×576 50P
<b>RAW Output Format</b> –	<b>1280×720P</b>	<b>1280×720P</b>	1280×720 50P
<b>Video Format</b> 1280×720 50P	–	720×576i	720×576 50i
	–	720×576P	720×576 50P
<b>RAW Output Format</b> 4096×2160 25P	<b>2048×1080PsF</b>	–	No output
<b>Video Format (fixed value)</b> 1920×1080 25P	1920×1080PsF	1920×1080i	1920×1080 25PsF
<b>RAW Output Format</b> –	–	4096×2160P	4096×2160 25P
<b>Video Format</b> 3840×2160 25P	–	<b>3840×2160P</b>	3840×2160 25P
	1920×1080PsF	1920×1080i	1920×1080 25PsF
<b>RAW Output Format</b> 2048×1080 25P	<b>2048×1080PsF</b>	–	No output
<b>Video Format (fixed value)</b> 1920×1080 25P	1920×1080PsF	1920×1080i	1920×1080 25PsF
<b>RAW Output Format</b> –	2048×1080PsF	–	No output
<b>Video Format</b> 1920×1080 25P	<b>1920×1080PsF</b>	1920×1080i	1920×1080 50i (PsF)
	–	720×576i	720×576 50i (PsF)
<b>RAW Output Format</b> –	<b>1280×720P</b>	1280×720P	1280×720 50P (2-2RP)
<b>Video Format</b> 1280×720 25P	–	720×576i	720×576 50i (PsF)

**Note**

No playback picture is output if the video output resolution is higher than the resolution of the picture.

## HDMI output settings for HDMI devices

Output Setting >HDMI Target Device in the Video menu	Output Display >SDI/HDMI in the Video menu	HDMI output	
		OSD On/Off	MLUT On/Off
<b>Recorder (default)</b>	SDI=On, HDMI=On (default) * Grayed out, cannot be selected.	–	Follows SDI1
	SDI=On, HDMI=Off	Off	
	SDI=Off, HDMI=Off	Off	
<b>Monitor</b>	SDI=On, HDMI=On (default)	On	Follows SDI2
	SDI=On, HDMI=Off * Grayed out, cannot be selected.	–	
	SDI=Off, HDMI=Off	Off	

### Note

If the current Output Display setting becomes unavailable for selection after changing HDMI Target Device, the Output Display setting changes as follows.

- Forcibly changes to the default value.
- If the default value is not available for selection, forcibly changes to “SDI=On, HDMI=On.”



## Operation Warnings

If a warning, caution, or operating condition that requires confirmation occurs on the camcorder, a message is displayed in the viewfinder, the recording indicators start flashing, and a warning sound is emitted.

The warning sound is emitted from the built-in speaker and headphones connected to the headphone connector.

## Error Messages

The camcorder will stop operation when the following kind of display occurs.

Viewfinder message	Warning sound	Recording indicator	Cause and Solution
E + error code	Continuous	High-speed flashing	Indicates an abnormality in the camcorder. Recording stops, even if ●REC is displayed in the viewfinder. Turn off the camcorder, and check for any problem with connected devices, cables, or media. If the error persists when the camcorder is turned on again, contact your Sony service representative. (If the camcorder does not turn off when the POWER switch is set to OFF, remove the battery or disconnect the DC IN supply.)

## Warning Messages

Follow the instructions provided if the following display occurs.

Viewfinder message	Warning sound	Recording indicator	Cause and Solution
Media Near Full	Intermittent	Flashing	The remaining capacity on the XQD memory card is getting low. Replace at the earliest convenience.
Media Full	Continuous	High-speed flashing	Clips could not be recorded, copied, or split because there is no remaining capacity on the XQD memory card. Replace immediately.
Battery Near End	Intermittent	Flashing	The remaining capacity of the battery pack is getting low. Recharge at the earliest convenience.
Battery End	Continuous	High-speed flashing	The battery pack is empty. Recording is disabled. Stop operation and replace the battery pack.
Temperature High	Intermittent	Flashing	The internal temperature is high. Turn off the camcorder and allow it to cool down before operating it again.
Voltage Low	Intermittent	Flashing	The DC IN voltage is low (level 1). Check the power source.
Insufficient Voltage	Continuous	High-speed flashing	The DC IN voltage is too low (level 2). Recording is disabled. Connect a different power source.

## Caution and Operation Messages

The following caution and operation messages may appear in the center of the screen. Follow the instructions provided to resolve the issue.

Viewfinder message	Cause and Solution
Battery Error Please Change Battery	An error was detected in the battery pack. Replace with a normal battery pack.
Backup Battery End Please Change	The remaining capacity of the backup battery is insufficient. Charge the backup battery.
Unknown Media(A) <sup>1)</sup> Please Change	A memory card that has been partitioned or a memory card containing more clips that can be handled by the camcorder was inserted. The card cannot be used in the camcorder, and must be replaced.
Cannot Use Media(A) <sup>1)</sup> Unsupported File System	A card using a different file system or an unformatted card was inserted. The card cannot be used in the camcorder, and must be replaced or formatted using the camcorder.
Media Error Media(A) <sup>1)</sup> Needs to be Restored	An error occurred on the memory card, and the card must be restored. Restore the memory card.
Media Error Cannot Record to Media(A) <sup>1)</sup>	The memory card may be damaged, and can no longer be used for recording. Playback is possible, so making a copy and replacing the memory card is recommended.
Media Error Cannot Use Media(A) <sup>1)</sup>	The memory card may be damaged, and can no longer be used for recording or playback. The card cannot be used in the camcorder, and must be replaced.
Media(A) <sup>1)</sup> Error Recording Halted Playback Halted	Recording and playback was stopped because an error occurred while using the memory card. If the problem persists, replace the memory card.
Media Reached Rewriting Limit Change Media (A) <sup>1)</sup>	The memory card has reached the end of its life. Make a backup, and replace the card immediately. If you continue using the card, the card may not be able to record or play.  <i>For details, refer to the operating instructions for the memory card.</i>
Fan Stopped	The built-in fan stopped. Avoid use at high temperatures, disconnect the power, and contact your Sony service representative.
Invalid setting value was reset: Media/Clip Naming/Camera Position Please save All File again	The Clip Naming format setting was reset because an invalid ALL file was loaded. Configure the desired format settings, and try to save the ALL file again.

1) "Media(B)" is displayed for the card in slot B.

## Licenses

### MPEG-4 Visual Patent Portfolio License

THIS PRODUCT IS LICENSED UNDER THE MPEG-4 VISUAL PATENT PORTFOLIO LICENSE FOR THE PERSONAL AND NON-COMMERCIAL USE OF A CONSUMER FOR

- (i) ENCODING VIDEO IN COMPLIANCE WITH THE MPEG-4 VISUAL STANDARD (“MPEG-4 VIDEO”) AND/OR
- (ii) DECODING MPEG-4 VIDEO THAT WAS ENCODED BY A CONSUMER ENGAGED IN A PERSONAL AND NON-COMMERCIAL ACTIVITY AND/OR WAS OBTAINED FROM A VIDEO PROVIDER LICENSED BY MPEG LA TO PROVIDE MPEG-4 VIDEO.

NO LICENSE IS GRANTED OR SHALL BE IMPLIED FOR ANY OTHER USE. ADDITIONAL INFORMATION INCLUDING THAT RELATING TO PROMOTIONAL, INTERNAL AND COMMERCIAL USES AND LICENSING MAY BE OBTAINED FROM MPEG LA, LLC. SEE [HTTP://WWW.MPEGLA.COM](http://WWW.MPEGLA.COM)

MPEG LA is offering licenses for (i) manufacturing/sales of any storage media storing MPEG-4 Visual video information (ii) distribution/broadcasting of MPEG-4 Visual video information in any manner (such as online video distribution service, internet broadcasting, TV broadcasting). Other usage of this product may be required to obtain license from MPEGLA. Please contact MPEG LA for any further information. MPEG LA, L.L.C., 250 STEELE STREET, SUITE 300, DENVER, COLORADO 80206, <http://www.mpegla.com>

### MPEG-2 Video Patent Portfolio License

ANY USE OF THIS PRODUCT OTHER THAN CONSUMER PERSONAL USE IN ANY MANNER THAT COMPLIES WITH THE MPEG-2 STANDARD FOR ENCODING VIDEO INFORMATION FOR PACKAGED MEDIA IS EXPRESSLY PROHIBITED WITHOUT A LICENSE UNDER APPLICABLE PATENTS IN THE MPEG-2 PATENT PORTFOLIO, WHICH LICENSE IS AVAILABLE FROM MPEG LA, L.L.C., 250 STEELE STREET, SUITE 300, DENVER, COLORADO 80206.

“PACKAGED MEDIA” means any storage media storing MPEG-2 video information such as DVD movie which are sold/distributed to general consumers. Disc replicators or sellers of the PACKAGED MEDIA need to obtain licenses for their own business from MPEG LA. Please contact MPEG LA for any further information. MPEG LA, L.L.C., 250 STEELE STREET, SUITE 300, DENVER, COLORADO 80206 <http://www.mpegla.com>

## Obtaining Software Under the GPL/LGPL License

This product uses software to which the GPL/LGPL applies. This informs you that you have a right to have access to, modify, and redistribute source code for these software programs under the conditions of the GPL/LGPL.

The source code is provided on the internet. Use the following URL and follow the download instructions.

<http://www.sony.net/Products/Linux/common/search.html>

We would prefer that you do not contact us about the contents of the source code.

For the content of these licenses, see "License1.pdf" in the "License" folder of the supplied CD-ROM.

Adobe Reader must be installed on your computer to view PDF files.

If Adobe Reader is not installed on your computer, you can download it by accessing the following URL.

<http://get.adobe.com/reader/>

## END USER LICENSE AGREEMENT

### IMPORTANT:

BEFORE USING THE SOFTWARE CONTAINED IN THE SOLID STATE MEMORY CAMCORDER, PLEASE READ THIS END USER LICENSE AGREEMENT ("EULA") CAREFULLY. BY USING THE SOFTWARE YOU ARE ACCEPTING THE TERMS OF THIS EULA. IF YOU DO NOT ACCEPT THE TERMS OF THIS EULA, YOU MAY NOT USE THE SOFTWARE.

This EULA is a legal agreement between you and Sony Corporation ("SONY"). This EULA governs your rights and obligations regarding the software of SONY and/or its third party licensors (including SONY's affiliates) and their respective affiliates (collectively, the "THIRD-PARTY SUPPLIERS") contained in the wireless adapter, together with any updates/ upgrades provided by SONY, any printed, on-line or other electronic documentation for such software, and any data files created by operation of such software (collectively, the "SOFTWARE").

Notwithstanding the foregoing, any software in the SOFTWARE having a separate end user license agreement (including, but not limited to, GNU General Public license and Lesser/Library General Public License) shall be covered by such applicable separate end user license agreement in lieu of the terms of this EULA to the extent required by such separate end user license agreement ("EXCLUDED SOFTWARE").

### SOFTWARE LICENSE

The SOFTWARE is licensed, not sold. The SOFTWARE is protected by copyright and other intellectual property laws and international treaties.

### COPYRIGHT

All right and title in and to the SOFTWARE (including, but not limited to, any images, photographs, animation, video, audio, music, text and "applets" incorporated into the SOFTWARE) is owned by SONY or one or more of the THIRD-PARTY SUPPLIERS.

### GRANT OF LICENSE

SONY grants you a limited license to use the SOFTWARE solely in connection with the

wireless adapter and only for your individual use. SONY and the THIRD-PARTY SUPPLIERS expressly reserve all rights, title and interest (including, but not limited to, all intellectual property rights) in and to the SOFTWARE that this EULA does not specifically grant to you.

#### **REQUIREMENTS AND LIMITATIONS**

You may not copy, publish, adapt, redistribute, attempt to derive source code, modify, reverse engineer, decompile, or disassemble any of the SOFTWARE, whether in whole or in part, or create any derivative works from or of the SOFTWARE unless such derivative works are intentionally facilitated by the SOFTWARE. You may not modify or tamper with any digital rights management functionality of the SOFTWARE. You may not bypass, modify, defeat or circumvent any of the functions or protections of the SOFTWARE or any mechanisms operatively linked to the SOFTWARE. You may not separate any individual component of the SOFTWARE for use on more than one wireless adapter unless expressly authorized to do so by SONY. You may not remove, alter, cover or deface any trademarks or notices on the SOFTWARE. You may not share, distribute, rent, lease, sublicense, assign, transfer or sell the SOFTWARE. The software, network services or other products other than SOFTWARE upon which the SOFTWARE'S performance depends might be interrupted or discontinued at the discretion of the suppliers (software suppliers, service suppliers, or SONY). SONY and such suppliers do not warrant that the SOFTWARE, network services, contents or other products will continue to be available, or will operate without interruption or modification.

#### **EXCLUDED SOFTWARE AND OPEN SOURCE COMPONENTS**

Notwithstanding the foregoing limited license grant, you acknowledge that the SOFTWARE may include EXCLUDED SOFTWARE. Certain EXCLUDED SOFTWARE may be covered by open source software licenses ("Open Source Components"), which means any software licenses approved as open source licenses by the Open Source Initiative or any substantially similar licenses, including but not limited to any license that, as a condition of distribution of the software licensed under such license, requires that the distributor make the software available in source code format. If and to the extent disclosure

is required, please visit [www.sony.com/linux](http://www.sony.com/linux) or other SONY-designated web site for a list of applicable OPEN SOURCE COMPONENTS included in the SOFTWARE from time to time, and the applicable terms and conditions governing its use. Such terms and conditions may be changed by the applicable third party at any time without liability to you. To the extent required by the licenses covering EXCLUDED SOFTWARE, the terms of such licenses will apply in lieu of the terms of this EULA. To the extent the terms of the licenses applicable to EXCLUDED SOFTWARE prohibit any of the restrictions in this EULA with respect to such EXCLUDED SOFTWARE, such restrictions will not apply to such EXCLUDED SOFTWARE. To the extent the terms of the licenses applicable to Open Source Components require SONY to make an offer to provide source code in connection with the SOFTWARE, such offer is hereby made.

#### **USE OF SOFTWARE WITH COPYRIGHTED MATERIALS**

The SOFTWARE may be capable of being used by you to view, store, process and/or use content created by you and/or third parties. Such content may be protected by copyright, other intellectual property laws, and/or agreements. You agree to use the SOFTWARE only in compliance with all such laws and agreements that apply to such content. You acknowledge and agree that SONY may take appropriate measures to protect the copyright of content stored, processed or used by the SOFTWARE. Such measures include, but are not limited to, counting the frequency of your backup and restoration through certain SOFTWARE features, refusal to accept your request to enable restoration of data, and termination of this EULA in the event of your illegitimate use of the SOFTWARE.

#### **CONTENT SERVICE**

PLEASE ALSO NOTE THAT THE SOFTWARE MAY BE DESIGNED TO BE USED WITH CONTENT AVAILABLE THROUGH ONE OR MORE CONTENT SERVICES ("CONTENT SERVICE"). USE OF THE SERVICE AND THAT CONTENT IS SUBJECT TO THE TERMS OF SERVICE OF THAT CONTENT SERVICE. IF YOU DECLINE TO ACCEPT THOSE TERMS, YOUR USE OF THE SOFTWARE WILL BE LIMITED. You acknowledge and agree that

certain content and services available through the SOFTWARE may be provided by third parties over which SONY has no control. USE OF THE CONTENT SERVICE REQUIRES AN INTERNET CONNECTION. THE CONTENT SERVICE MAY BE DISCONTINUED AT ANY TIME.

#### **INTERNET CONNECTIVITY AND THIRD PARTY SERVICES**

You acknowledge and agree that access to certain SOFTWARE features may require an Internet connection for which you are solely responsible. Further, you are solely responsible for payment of any third party fees associated with your Internet connection, including but not limited to Internet service provider or airtime charges. Operation of the SOFTWARE may be limited or restricted depending on the capabilities, bandwidth or technical limitations of your Internet connection and service. The provision, quality and security of such Internet connectivity are the sole responsibility of the third party providing such service.

#### **EXPORT AND OTHER REGULATIONS**

You agree to comply with all applicable export and re-export restrictions and regulations of the area or country in which you reside, and not to transfer, or authorize the transfer, of the SOFTWARE to a prohibited country or otherwise in violation of any such restrictions or regulations.

#### **HIGH RISK ACTIVITIES**

The SOFTWARE is not fault-tolerant and is not designed, manufactured or intended for use or resale as on-line control equipment in hazardous environments requiring fail-safe performance, such as in the operation of nuclear facilities, aircraft navigation or communication systems, air traffic control, direct life support machines, or weapons systems, in which the failure of the SOFTWARE could lead to death, personal injury, or severe physical or environmental damage (“HIGH RISK ACTIVITIES”). SONY, each of the THIRD-PARTY SUPPLIERS, and each of their respective affiliates specifically disclaim any express or implied warranty, duty or condition of fitness for HIGH RISK ACTIVITIES.

#### **EXCLUSION OF WARRANTY ON SOFTWARE**

You acknowledge and agree that use of the SOFTWARE is at your sole risk and that you are responsible for use of the SOFTWARE. The SOFTWARE is provided “AS IS,” without warranty, duty or condition of any kind.

SONY AND EACH OF THE THIRD-PARTY SUPPLIERS (for purposes of this Section, SONY and each of the THIRD-PARTY SUPPLIERS shall be collectively referred to as “SONY”) EXPRESSLY DISCLAIM ALL WARRANTIES, DUTIES OR CONDITIONS, EXPRESS OR IMPLIED, INCLUDING, BUT NOT LIMITED TO, THE IMPLIED WARRANTIES OF MERCHANTABILITY, NONINFRINGEMENT AND FITNESS FOR A PARTICULAR PURPOSE. SONY DOES NOT WARRANT OR MAKE ANY CONDITIONS OR REPRESENTATIONS (A) THAT THE FUNCTIONS CONTAINED IN ANY OF THE SOFTWARE WILL MEET YOUR REQUIREMENTS OR THAT THEY WILL BE UPDATED, (B) THAT THE OPERATION OF ANY OF THE SOFTWARE WILL BE CORRECT OR ERROR-FREE OR THAT ANY DEFECTS WILL BE CORRECTED, (C) THAT THE SOFTWARE WILL NOT DAMAGE ANY OTHER SOFTWARE, HARDWARE OR DATA, (D) THAT ANY SOFTWARE, NETWORK SERVICES (INCLUDING THE INTERNET) OR PRODUCTS (OTHER THAN THE SOFTWARE) UPON WHICH THE SOFTWARE’S PERFORMANCE DEPENDS WILL CONTINUE TO BE AVAILABLE, UNINTERRUPTED OR UNMODIFIED, AND (E) REGARDING THE USE OR THE RESULTS OF THE USE OF THE SOFTWARE IN TERMS OF ITS CORRECTNESS, ACCURACY, RELIABILITY, OR OTHERWISE.

NO ORAL OR WRITTEN INFORMATION OR ADVICE GIVEN BY SONY OR AN AUTHORIZED REPRESENTATIVE OF SONY SHALL CREATE A WARRANTY, DUTY OR CONDITION OR IN ANY WAY INCREASE THE SCOPE OF THIS WARRANTY. SHOULD THE SOFTWARE PROVE DEFECTIVE YOU ASSUME THE ENTIRE COST OF ALL NECESSARY SERVICING, REPAIR OR

CORRECTION. SOME JURISDICTIONS DO NOT ALLOW THE EXCLUSION OF IMPLIED WARRANTIES, SO THESE EXCLUSIONS MAY NOT APPLY TO YOU.

**LIMITATION OF LIABILITY**

SONY AND EACH OF THE THIRD-PARTY SUPPLIERS (for purposes of this Section, SONY and each of the THIRD-PARTY SUPPLIERS shall be collectively referred to as “SONY”) SHALL NOT BE LIABLE FOR ANY INCIDENTAL OR CONSEQUENTIAL DAMAGES FOR BREACH OF ANY EXPRESS OR IMPLIED WARRANTY, BREACH OF CONTRACT, NEGLIGENCE, STRICT LIABILITY OR UNDER ANY OTHER LEGAL THEORY RELATED TO THE SOFTWARE, INCLUDING, BUT NOT LIMITED TO, ANY DAMAGES ARISING OUT OF LOSS OF PROFITS, LOSS OF REVENUE, LOSS OF DATA, LOSS OF USE OF THE SOFTWARE OR ANY ASSOCIATED HARDWARE, DOWN TIME AND USER’ S TIME, EVEN IF ANY OF THEM HAVE BEEN ADVISED OF THE POSSIBILITY OF SUCH DAMAGES. IN ANY CASE, EACH AND ALL OF THEIR AGGREGATE LIABILITY UNDER ANY PROVISION OF THIS EULA SHALL BE LIMITED TO THE AMOUNT ACTUALLY PAID FOR THE PRODUCT. SOME JURISDICTIONS DO NOT ALLOW THE EXCLUSION OR LIMITATION OF INCIDENTAL OR CONSEQUENTIAL DAMAGES, SO THE ABOVE EXCLUSION OR LIMITATION MAY NOT APPLY TO YOU.

**CONSENT TO USE OF NON-PERSONAL INFORMATION, LOCATION DATA, DATA SECURITY**

You acknowledge and agree that SONY and its affiliates, partners and agents may read, collect, transfer, process and store certain information collected from the SOFTWARE, including but not limited to information about (i) the SOFTWARE and (ii) the software applications, contents and peripheral devices that interact with your wireless adapter and the SOFTWARE (“Information”). Information includes, but is not limited to: (1) unique identifiers relating to your wireless adapter and its components; (2) performance of the wireless adapter, the SOFTWARE and their components; (3)

configurations of your wireless adapter, the SOFTWARE and the software applications, contents and peripheral devices that interact with the wireless adapter and the SOFTWARE; (4) use and frequency of use of the functions of (x) the SOFTWARE, and (y) the software applications, contents and peripheral devices that interact with the SOFTWARE; and (5) location data, as indicated below. SONY and its affiliates, partners and agents may use and disclose Information subject to applicable laws in order to improve its products and services or to provide products or services to you. Such uses include, but are not limited to: (a) administering the functionalities of the SOFTWARE; (b) to improve, service, update or upgrade the SOFTWARE; (c) improving, developing and enhancing the current and future products and services of SONY and other parties; (d) to provide you with information about the products and services offered by SONY and other parties; (e) complying with applicable laws or regulations; and (f) to the extent offered, providing you with location-based services of SONY and other parties, as indicated below. In addition, SONY retains the right to use Information to protect itself and third parties from illegal, criminal or harmful conduct.

Certain services available through the SOFTWARE may rely upon location information, including, but not limited to, the geographic location of the wireless adapter. You acknowledge that for the purpose of providing such services, SONY, the THIRDPARTY SUPPLIERS or their partners may collect, archive, process and use such location data, and that such services are governed by the privacy policies of SONY or such third party. By reviewed the privacy policies applicable to such services and consent to such activities.

SONY, its affiliates, partners and agents will not intentionally use Information to personally identify the owner or user of the SOFTWARE without your knowledge or consent. Any use of Information will be in accordance with the privacy policies of SONY or such third party.

Please contact applicable contact address of each area or country for SONY’ s current privacy policy. Please contact applicable third parties for privacy policies relating to personally identifiable

and other information you provide when you use or access third party software or services.

Information may be processed, stored or transferred to SONY, its affiliates or agents which are located in countries outside of your country of residence. Data protection and information privacy laws in certain countries may not offer the same level of protection as your country of residence and you may have fewer legal rights in relation to Information processed and stored in, or transferred to, such countries. SONY will use reasonable efforts to take appropriate technical and organizational steps to prevent unauthorized access to or disclosure of Information, but does not warrant it will eliminate all risk of misuse of such Information.

#### **AUTOMATIC UPDATE FEATURE**

From time to time, SONY or the THIRD-PARTY SUPPLIERS may automatically update or otherwise modify the SOFTWARE, including, but not limited to, for purposes of enhancement of security functions, error correction and improvement of functions, at such time as you interact with SONY' s or third parties' servers, or otherwise. Such updates or modifications may delete or change the nature of features or other aspects of the SOFTWARE, including, but not limited to, functions you may rely upon. You acknowledge and agree that such activities may occur at SONY' s sole discretion and that SONY may condition continued use of the SOFTWARE upon your complete installation or acceptance of such update or modifications. Any updates/ modifications shall be deemed to be, and shall constitute part of, the SOFTWARE for purposes of this EULA. By acceptance of this EULA, you consent to such update/modification.

#### **ENTIRE AGREEMENT, WAIVER, SEVERABILITY**

This EULA and SONY' s privacy policy, each as amended and modified from time to time, together constitute the entire agreement between you and SONY with respect to the SOFTWARE. The failure of SONY to exercise or enforce any right or provision of this EULA shall not constitute a waiver of such right or provision. If any part of this EULA is held invalid, illegal, or unenforceable, that provision shall be enforced to the maximum extent permissible so as to maintain

the intent of this EULA, and the other parts will remain in full force and effect.

#### **GOVERNING LAW AND JURISDICTION**

The United Nations Convention on Contracts for the International Sale of Goods shall not apply to this EULA. This EULA shall be governed by the laws of Japan, without regards to conflict of laws provisions. Any dispute arising out of this EULA shall be subject to the exclusive venue of the Tokyo District Court in Japan, and the parties hereby consent to the venue and jurisdiction of such courts.

#### **EQUITABLE REMEDIES**

Notwithstanding anything contained in this EULA to the contrary, you acknowledge and agree that any violation of or noncompliance with this EULA by you will cause irreparable harm to SONY, for which monetary damages would be inadequate, and you consent to SONY obtaining any injunctive or equitable relief that SONY deems necessary or appropriate in such circumstances. SONY may also take any legal and technical remedies to prevent violation of and/or to enforce this EULA, including, but not limited to, immediate termination of your use of the SOFTWARE, if SONY believes in its sole discretion that you are violating or intend to violate this EULA. These remedies are in addition to any other remedies SONY may have at law, in equity or under contract.

#### **TERMINATION**

Without prejudice to any of its other rights, SONY may terminate this EULA if you fail to comply with any of its terms. In case of such termination, you must: (i) cease all use, and destroy any copies, of the SOFTWARE; (ii) comply with the requirements in the section below entitled "Your Account Responsibilities".

#### **AMENDMENT**

SONY RESERVES THE RIGHT TO AMEND ANY OF THE TERMS OF THIS EULA AT ITS SOLE DISCRETION BY POSTING NOTICE ON A SONY DESIGNATED WEB SITE, BY EMAIL NOTIFICATION TO AN EMAIL ADDRESS PROVIDED BY YOU, BY PROVIDING NOTICE AS PART OF THE PROCESS IN WHICH YOU OBTAIN UPGRADES/ UPDATES OR BY ANY OTHER LEGALLY RECOGNIZABLE FORM OF NOTICE. If you do not agree to the amendment,



you should promptly contact SONY for instructions. Your continued use of the SOFTWARE after the effective date of any such notice shall be deemed your agreement to be bound by such amendment.

### THIRD-PARTY BENEFICIARIES

Each THIRD-PARTY SUPPLIER is an express intended thirdparty beneficiary of, and shall have the right to enforce, each provision of this EULA with respect to the SOFTWARE of such party.

Should you have any questions concerning this EULA, you may contact SONY by writing to SONY at applicable contact address of each area or country.

Copyright © 2012 Sony Corporation.

## Open Software Licenses

On the basis of license contracts between Sony and the software copyright holders, this product uses open software.

To meet the requirements of the software copyright holders, Sony is obligated to inform you of the content of these licenses.

For the content of these licenses, see “License1.pdf” in the “License” folder of the supplied CD-ROM.

## Specifications

### General

Mass Approx. 2.0 kg (4 lb 6.5 oz) (body only)

Dimensions

(Unit: mm (inch), body only)<sup>1)</sup>

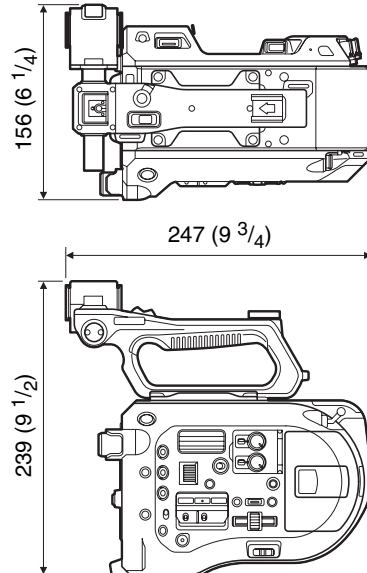

1) The values for dimensions are approximate.

Power requirement

12 V DC (11 V to 17.0 V)

Power consumption

Approx. 19 W (body, SELP28135G lens, XAVC-I QFHD 59.94P recording, viewfinder on)

Operating temperature

0 °C to 40 °C (32 °F to 104 °F)

Storage temperature

-20 °C to +60 °C (-4 °F to +140 °C)

Continuous operating time

Approx. 60 minutes (using BP-U30)

Recording format (video)

**XAVC Intra**

AVC/H.264 High 4:2:2 Intra Profile

QFHD: CBG, 600 Mbps

HD: CBG, 222 Mbps

**XAVC Long**

AVC/H.264 High Profile

QFHD: VBR, 150 Mbps max., 4:2:0

Long

HD: VBR, 50 Mbps max., 4:2:2 Long <b>MPEG HD422</b> MPEG-2 Long GOP HD422 mode: CBR, 50 Mbps, MPEG-2 422P@HL	Approx. 26 minutes: Using QD-G64A
Recording format (audio) LPCM 24-bit, 48 kHz, 4-channel (2-channel recording on camcorder)	
Recording frame rate <b>XAVC Intra</b> 3840 × 2160/59.94P, 50P, 29.97P, 23.98P, 25P 1920 × 1080/59.94P, 50P, 59.94i, 50i, 29.97P, 23.98P, 25P <b>XAVC Long</b> 3840 × 2160/59.94P, 50P, 29.97P, 23.98P, 25P 1920 × 1080/59.94P, 50P, 59.94i, 50i, 29.97P, 23.98P, 25P <b>MPEG HD 422</b> 1920 × 1080/59.94i, 50i, 29.97P, 23.98P, 25P 1280 × 720/59.94P, 50P, 29.97P, 23.98P, 25P	<b>XAVC Intra 1920 × 1080</b> 59.94P Approx. 59 minutes: Using QD-G128A Approx. 30 minutes: Using QD-G64A 50P Approx. 71 minutes: Using QD-G128A Approx. 35 minutes: Using QD-G64A 59.94i Approx. 118 minutes: Using QD-G128A Approx. 59 minutes: Using QD-G64A 50i Approx. 141 minutes: Using QD-G128A Approx. 70 minutes: Using QD-G64A 29.97P Approx. 118 minutes: Using QD-G128A Approx. 59 minutes: Using QD-G64A 23.98P Approx. 147 minutes: Using QD-G128A Approx. 74 minutes: Using QD-G64A 25P Approx. 141 minutes: Using QD-G128A Approx. 70 minutes: Using QD-G64A
Recording/playback time <b>XAVC Intra 3840 × 2160</b> 59.94P Approx. 22 minutes: Using QD-G128A Approx. 11 minutes: Using QD-G64A 50P Approx. 26 minutes: Using QD-G128A Approx. 13 minutes: Using QD-G64A 29.97P Approx. 44 minutes: Using QD-G128A Approx. 22 minutes: Using QD-G64A 23.98P Approx. 55 minutes: Using QD-G128A Approx. 27 minutes: Using QD-G64A 25P Approx. 52 minutes: Using QD-G128A	<b>XAVC Long 3840 × 2160</b> 59.94P/50P Approx. 87 minutes: Using QD-G128A Approx. 44 minutes: Using QD-G64A 29.97P/23.98P/25P Approx. 131 minutes: Using QD-G128A Approx. 66 minutes: Using QD-G64A

### **XAVC Long 1920 × 1080**

- 50M mode
  - Approx. 262 minutes: Using QD-G128A
  - Approx. 131 minutes: Using QD-G64A
- 35M mode
  - Approx. 374 minutes: Using QD-G128A
  - Approx. 187 minutes: Using QD-G64A
- 25M mode
  - Approx. 524 minutes: Using QD-G128A
  - Approx. 262 minutes: Using QD-G64A

### **MPEG HD 422**

- Approx. 262 minutes: Using QD-G128A
- Approx. 131 minutes: Using QD-G64A

#### **Note**

The recording/playback time may vary due to usage conditions and memory characteristics.

## **Camera Section**

- Imaging device (type)
  - Super 35 equivalent CMOS image sensor
- Number of pixels
  - 11.6 Megapixels (total),
  - 8.8 Megapixels@17:9/
  - 8.3 Megapixels@16:9 (effective)
- ND filters
  - 1: Clear
  - 2: 1/4ND
  - 3: 1/16ND
  - 4: 1/64ND
- Sensitivity
  - Video Gamma: T14 @ 24p
  - (2000 lx, 89.9% reflectance, 3200K)
- ISO sensitivity
  - S-Log3 Gamma ISO2000 (D55 light source)
- Minimum illumination
  - 0.7 lx (18 dB, 23.98P, Shutter: OFF, ND Clear, F1.4)
- Lens mount
  - E-mount

- Latitude
  - 14-stop
- Video S/N
  - 57 dB (Video Gamma/Noise Suppression: off)
- Shutter speed
  - 1/3 to 1/9000 sec. (23.98P)
- Shutter angle
  - 4.2° to 359.7°
  - 5.6° to 180° (23.98P)
  - 5.6° to 216° (59.94P)
  - 5.6° to 300° (50P)
- Slow & Quick Motion
  - XAVC QFHD: 1 to 60P,
  - XAVC HD: 1 to 180P
- White balance
  - Preset mode, Memory mode A, B (1500K to 50000K)
- Gain
  - 3, 0, 3, 6, 9, 12, 18 dB
- Gamma curve
  - STD1, STD2, STD3, STD4, STD5, STD6, HG1, HG2, HG3, HG7, HG8, S-Log3, USER1, USER2, USER3, USER4

## **Audio Section**

- Sampling frequency
  - 48 kHz
- Quantization
  - 24-bit
- Frequency response
  - 50 Hz to 20 kHz (±3 dB or less)
- Dynamic range
  - 90 dB (typical)
- Distortion
  - 0.08% or lower (-40 dBu input level)
- Built-in speaker
  - Monaural
- Built-in microphone
  - Monaural

## **Input/Output Section**

### **Inputs**

- INPUT 1/2:
  - XLR type, 3-pin, female
  - LINE / MIC / MIC+48V switchable
  - MIC: Reference -40, -50, -60 dBu

### **Outputs**

- SDI OUT 1/2:

BNC type, 0.8 Vp-p, unbalanced (3G HD/1.5G HD output)  
 SMPTE ST424/425 Level-A/B, 292M standard compliant  
 4-channel audio

EARPHONE (stereo mini jack):  
 -16 dBu (reference level output, maximum monitor volume, 16 Ω load)

HDMI: Type A, 19-pin

**Other**  
 DC IN: EIAJ compliant, 11 V to 17 V DC  
 Extension unit connector:  
 Dedicated (144-pin)  
 Multi-interface shoe:  
 Dedicated (21-pin)

REMOTE:  
 2.5 Φ 3-pole sub-mini type

USB: 2.0 standard compliant, type AB mini for mass storage (1)  
 Type A for W-LAN connection (1)

VF: Dedicated (40-pin)

## Display Section

LCD monitor  
 Screen size  
 8.8 cm (3.5 inch) diagonal  
 Aspect ratio  
 16:9  
 Number of pixels  
 960 (H) × 540 (V)

## Media Slot Section

XQD card slots for video recording (2)  
 UTILITY SD card slot (1)

## Supplied Accessories

Viewfinder (including eyepiece, eyecup, rod, clamp)  
 Grip remote control  
 USB wireless LAN module (IFU-WLM3)  
 Infrared remote control (RMT-845)  
 AC Adaptor  
 MPA-AC1 (USA and Canada model only)  
 Rated input: 100 V to 240 V AC, 50 Hz/60 Hz, 0.4 A to 0.75 A  
 Rated output: 12 V DC, 3 A

AC-NB12A (except USA and Canada model)  
 Rated input: 100 V to 240 V AC, 50 Hz/60 Hz, 0.35 A to 0.65 A  
 Rated output: 12 V DC, 2.5 A

Battery pack (BP-U30)  
 Maximum voltage: 16.4 V DC  
 Nominal voltage: 14.4 V DC  
 Capacity: 28 Wh

Battery charger (BC-U1)  
 Power requirements: 100 V to 240 V AC, 50 Hz/60 Hz  
 Power consumption: 38 W  
 Rated output: Charging 16.4 V, 1.9 A/1.5 A

Power cords (2)  
 Mini USB cable (1)  
 Option mounting stay (1)  
 Lens mount cap (1)  
 Handle connector protective cap (including two M2 screws) (1)  
 USB wireless LAN module cap (1)  
 W-LAN connector cover spare (1)  
 Extension unit connector cover spare (1)  
 Accessory shoe kit (accessory shoe (1), shoe plate (1), screws (4))  
 Before Using this Unit (1)  
 Operating Instructions (CD-ROM) (1)

Design and specifications are subject to change without notice.

SONY WILL NOT BE LIABLE FOR DAMAGES OF ANY KIND RESULTING FROM A FAILURE TO IMPLEMENT PROPER SECURITY MEASURES ON TRANSMISSION DEVICES, UNAVOIDABLE DATA LEAKS RESULTING FROM TRANSMISSION SPECIFICATIONS, OR SECURITY PROBLEMS OF ANY KIND.

#### Notes

- Always make a test recording, and verify that it was recorded successfully.  
SONY WILL NOT BE LIABLE FOR DAMAGES OF ANY KIND INCLUDING, BUT NOT LIMITED TO, COMPENSATION OR REIMBURSEMENT ON ACCOUNT OF FAILURE OF THIS UNIT OR ITS RECORDING MEDIA, EXTERNAL STORAGE SYSTEMS OR ANY OTHER MEDIA OR STORAGE SYSTEMS TO RECORD CONTENT OF ANY TYPE.
- Always verify that the unit is operating properly before use.  
SONY WILL NOT BE LIABLE FOR DAMAGES OF ANY KIND INCLUDING, BUT NOT LIMITED TO, COMPENSATION OR REIMBURSEMENT ON ACCOUNT OF THE LOSS OF PRESENT OR PROSPECTIVE PROFITS DUE TO FAILURE OF THIS UNIT, EITHER DURING THE WARRANTY PERIOD OR AFTER EXPIRATION OF THE WARRANTY, OR FOR ANY OTHER REASON WHATSOEVER.
- SONY WILL NOT BE LIABLE FOR CLAIMS OF ANY KIND MADE BY USERS OF THIS UNIT OR MADE BY THIRD PARTIES.
- SONY WILL NOT BE LIABLE FOR THE LOSS, REPAIR, OR REPRODUCTION OF ANY DATA RECORDED ON THE INTERNAL STORAGE SYSTEM, RECORDING MEDIA, EXTERNAL STORAGE SYSTEMS OR ANY OTHER MEDIA OR STORAGE SYSTEMS.
- SONY WILL NOT BE LIABLE FOR THE TERMINATION OR DISCONTINUATION OF ANY SERVICES RELATED TO THIS UNIT THAT MAY RESULT DUE TO CIRCUMSTANCES OF ANY KIND.

## Software Downloads

When the unit is used with a PC connection, download device drivers, plug-ins, and application software, where applicable, from the Sony Professional products web site.

Sony Professional products web site homepage:

U.S.A	<a href="http://pro.sony.com">http://pro.sony.com</a>
Canada	<a href="http://www.sonybiz.ca">http://www.sonybiz.ca</a>
Latin America	<a href="http://sonypro-latin.com">http://sonypro-latin.com</a>
Europe	<a href="http://www.pro.sony.eu/pro">http://www.pro.sony.eu/pro</a>
Middle East and Africa	<a href="http://sony-psmea.com">http://sony-psmea.com</a>
Russia	<a href="http://sony.ru/pro/">http://sony.ru/pro/</a>
Brazil	<a href="http://sonypro.com.br">http://sonypro.com.br</a>
Australia	<a href="http://pro.sony.com.au">http://pro.sony.com.au</a>
New Zealand	<a href="http://pro.sony.co.nz">http://pro.sony.co.nz</a>
Japan	<a href="http://www.sonybsc.com">http://www.sonybsc.com</a>
Asia	<a href="http://pro.sony-asia.com">http://pro.sony-asia.com</a>
Korea	<a href="http://bp.sony.co.kr">http://bp.sony.co.kr</a>
China	<a href="http://pro.sony.com.cn">http://pro.sony.com.cn</a>
India	<a href="http://pro.sony.co.in">http://pro.sony.co.in</a>

Sony Creative Software, software download page  
[http://www.sonycreativesoftware.com/download/software\\_for\\_sony\\_equipment](http://www.sonycreativesoftware.com/download/software_for_sony_equipment)

## Trademarks

XDCAM is a trademark of Sony Corporation.

- XAVC and **XAVC** are registered trademarks of Sony Corporation.
- XQD and **XQD** are trademarks of Sony Corporation.
- HDMI, the HDMI logo, and High-Definition Multimedia Interface are trademarks or registered trademarks of HDMI Licensing, LLC in the United States and/or other countries.

All other company names and product names are registered trademarks or trademarks of their respective owners. Trademarked items are not indicated by ® or ™ symbols in this document.

<http://www.sony.net/>